

Model Name: 945P-S3

SHEET TITLE

01	COVER SHEET
02	BLOCK DIAGRAM
03	BOM & PCB MODIFY HISTORY
04	L775_A
05	L775_B,D
06	L775_C
07	L775_E,F,G,H
08	BROADWATER HOST
09	BROADWATER DDR
10	BROADWATER PCI_EXP_16,DMI
11	BROADWATER VGA,MISC
12	BROADWATER GND
13	BROADWATER PWR
14	DDRII CHANNEL A-SHARE 1,2
15	DDRII CHANNEL B-SHARE 1,2
16	DDRII TERMINATION
17	PCI EXPRESS*16 SLOT
18	ICH7 DMI, PCI, USB
19	ICH7 IDE, GPIO, SATA, CTRL
20	ICH7 VCC, GND
21	ICS9LPRS587 CLOCK.
22	ATX,ATX_12V CONNECT,BIOS
23	PCI EXPRESS*1 SLOT 1,2,3
24	PCI SLOT 1,2,3
25	HWM/ FAN CONTROL
26	IDE/FLOPPY
27	KB_PS2

SHEET TITLE

28	FRONT PANEL
29	FRONT USB,REAL USB CONNECT
30	PROCESSOR HOT
31	ALC883
32	REAR AUDIO JACK
33	FRONT AUDIO CONNECTOR
34	MARVELL 88E8056
35	ITE 8712/8718 GBKX
36	COM_LPT
37	VCORE PWM
38	DISCRETE POWER
39	GPIO DEFINE
40	GPIO DEFINE
41	
42	
43	
44	

Intel Confidential

Title		
Cover Sheet		
Size	Document Number	Rev
Custom	945P-S3	1.01
Date:	Wednesday, August 02, 2006	Sheet 1 of 40

BLOCK DIAGRAM

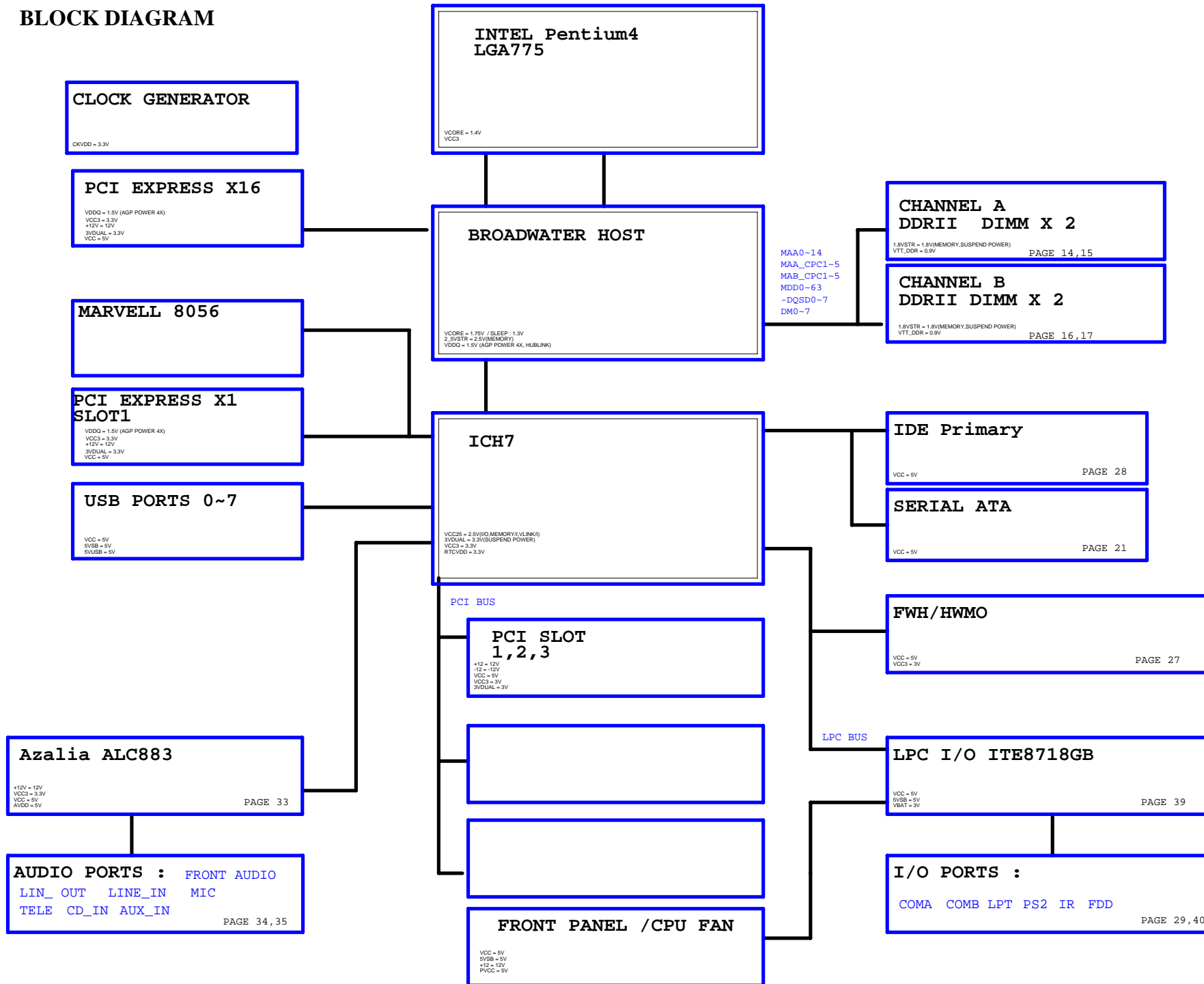

Model Name: 945P-S3
Version:1.01

Circuit or PCB layout change
for next version

Component value change
history

2006

Data	Change Item	Reason
1.0A	EVT Release	
1.0B	1. PCB Rev1.0 --> REv1.01	
	2. DR68 200/6 --> 300/6	
	3. PROCHOT R379 2K/6/1 --> 1.78K/6/1	
	4.包材修改	
	5. ADD COMP8 R101=30/6/1	
	6. PROCHOT & STPCLK D13=BAT54A REMOVE	
	7. CONROE 266MHZ --> 133MHZ R189=8.2K/4 , R169=22K/4 , ADD BC51 0.1U/4	
	8. DDRVTT ADD BC79,BC84=0.1U/6/Y5V/25V/Z	
	9. BC465,BC467,BC464,BC461 加替料	
	10CM3-041005-51R/54R/56R/57R/2AR	
	10. REMOVE PCI_BT1 , PCI_BT2	
1.0C	1. LPC DUAL BIOS SELECT REMOVE R458 , ADD R459=1K/4	
	2. RTL8111B ADD CAP FOR LBC45,35,55=0.1U/6 , LEC4,LEC6=100u/D	

DATE	Change Item	Reason
1.0	1. GA-945PL-S3 Rev1.01 --> GA-945P-S3 Rev1.0	
1.01	文字面 Dual Channel DDRII 移除	
	LAN LED LD1 REMOVE	

HA/REQ: 5/13
ADSTB: 5/17

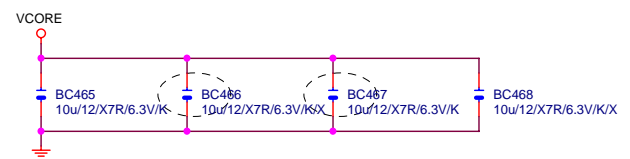
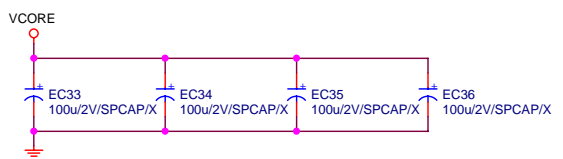
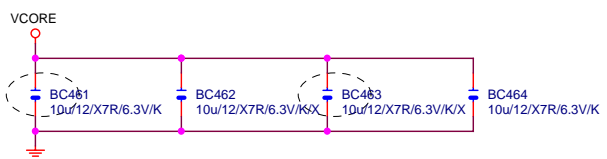
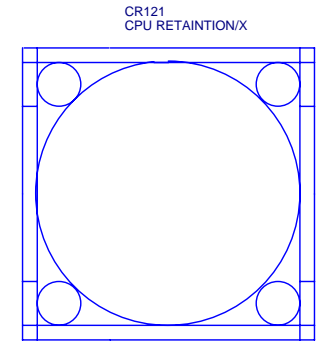
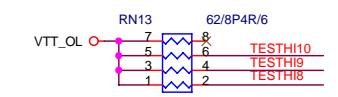
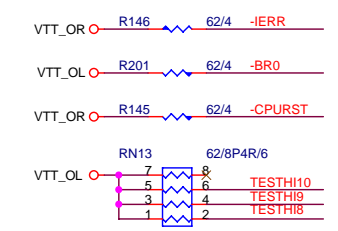
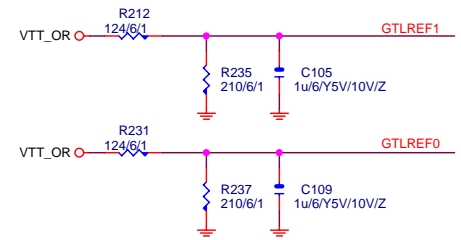
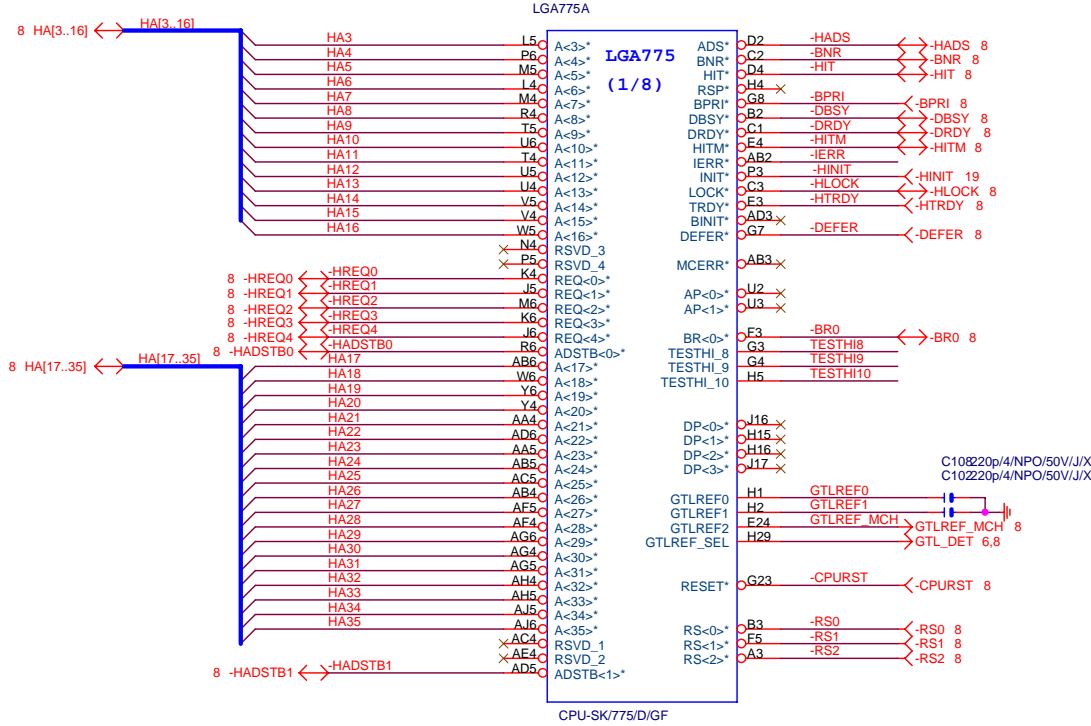

Gigabyte Technology		
Title P4_LGA775-A		
Size B	Document Number 945P-S3	Rev 1.0
Date:	Wednesday, August 02, 2006	Sheet 4 of 40

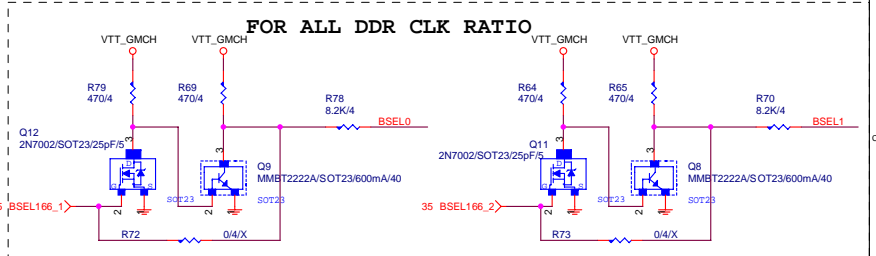
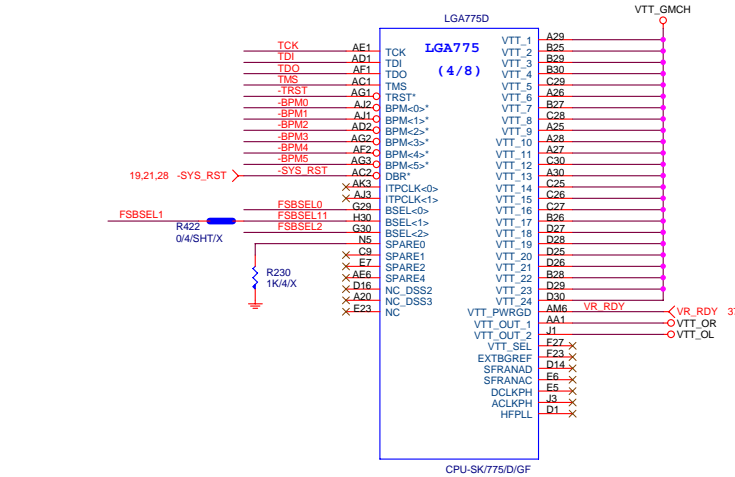
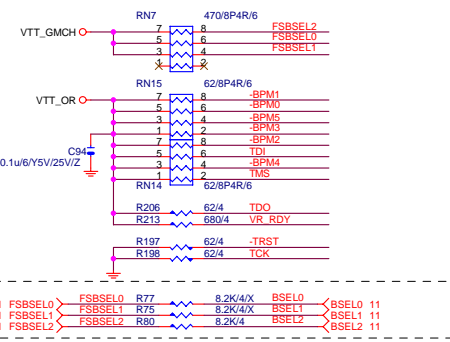
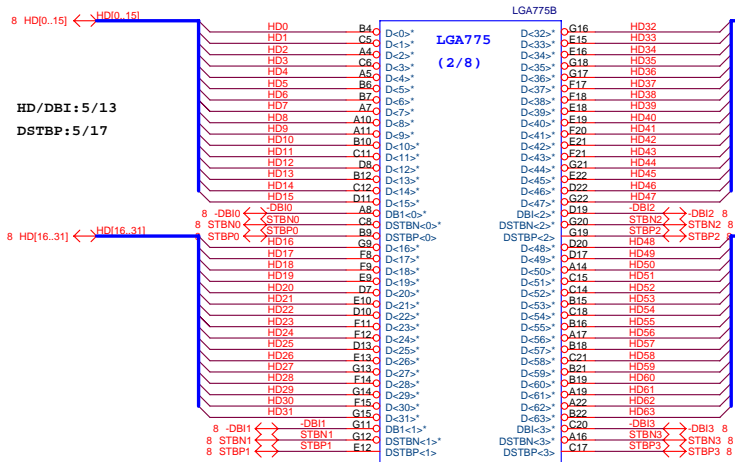

CHECK BSEL0/1 ITE8712 POWER ON 時電壓是否會高於1.2V

CPU

FSBSEL0	FSBSEL1	FSBSEL2	Clock	
1	0	1	100MHz	
1	0	0	1.33MHz	3/4
1	1	0	166MHz	# POWER ON
0	1	0	200MHz	2.0/2.66/3.33
0	0	0	266MHz	1.5/2.0/2.5

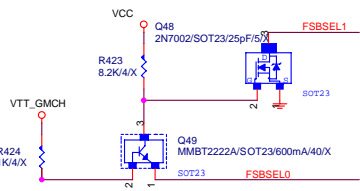

Note:
VCCA & VCOREPLL
define doesn't same as
old P4 design kit

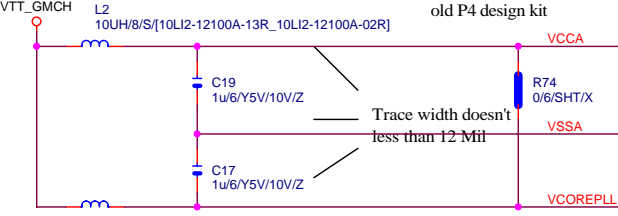

As close as possible to
CPU socket

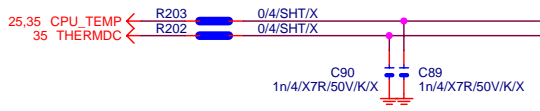
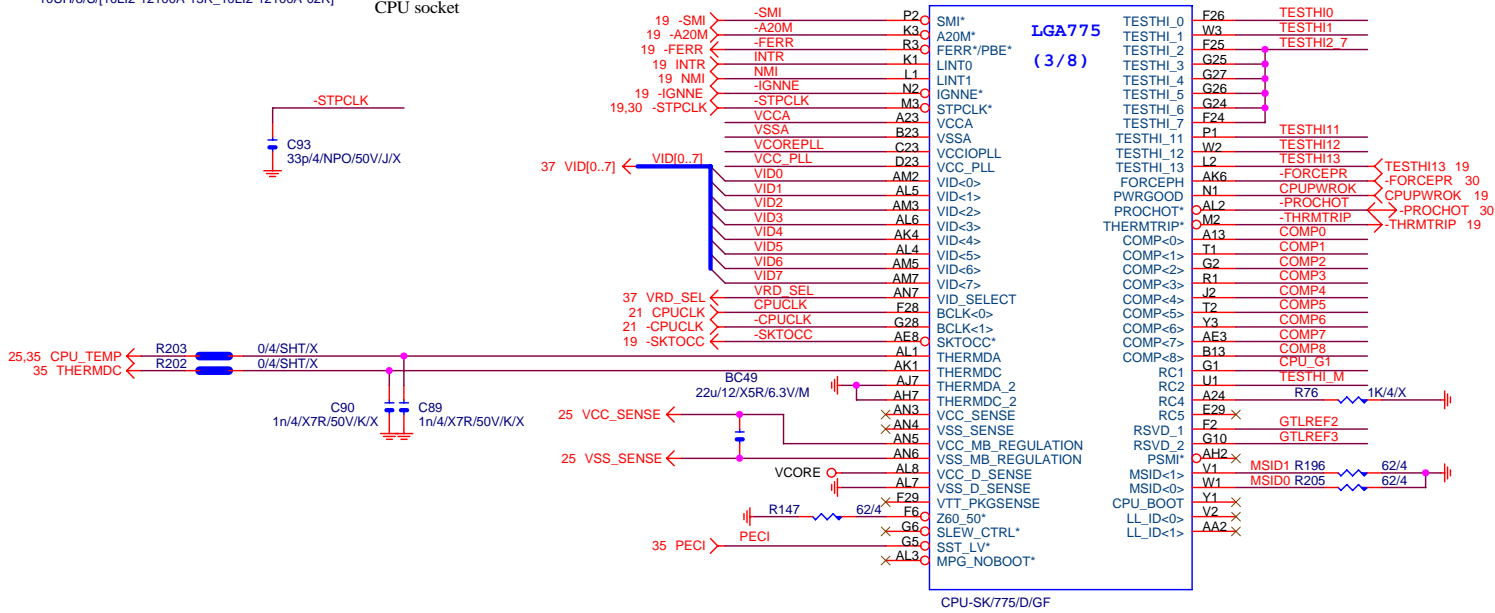
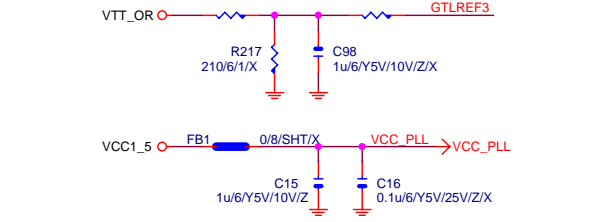
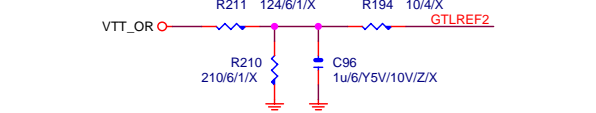
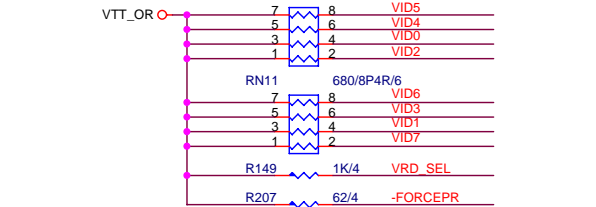
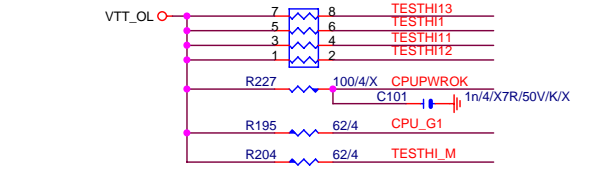
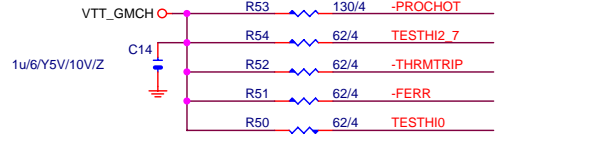
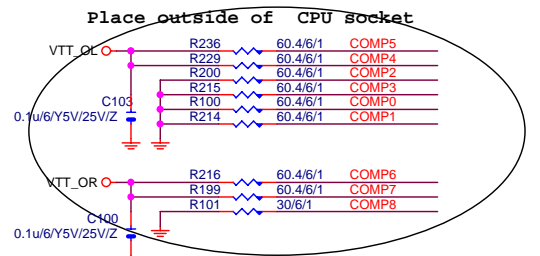
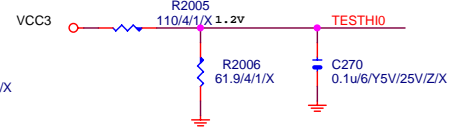
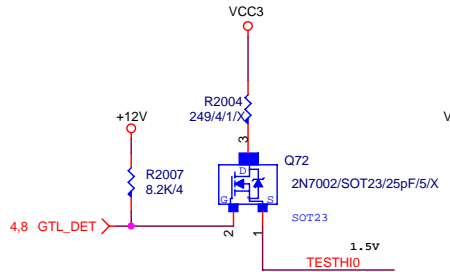

Gigabyte Technology		
Title P4_LGA775-C		
Size B	Document Number 945P-S3	Rev 1.0
Date:	Wednesday, August 02, 2006	Sheet 6 of 40

PECI:Platform Environment Control Interface

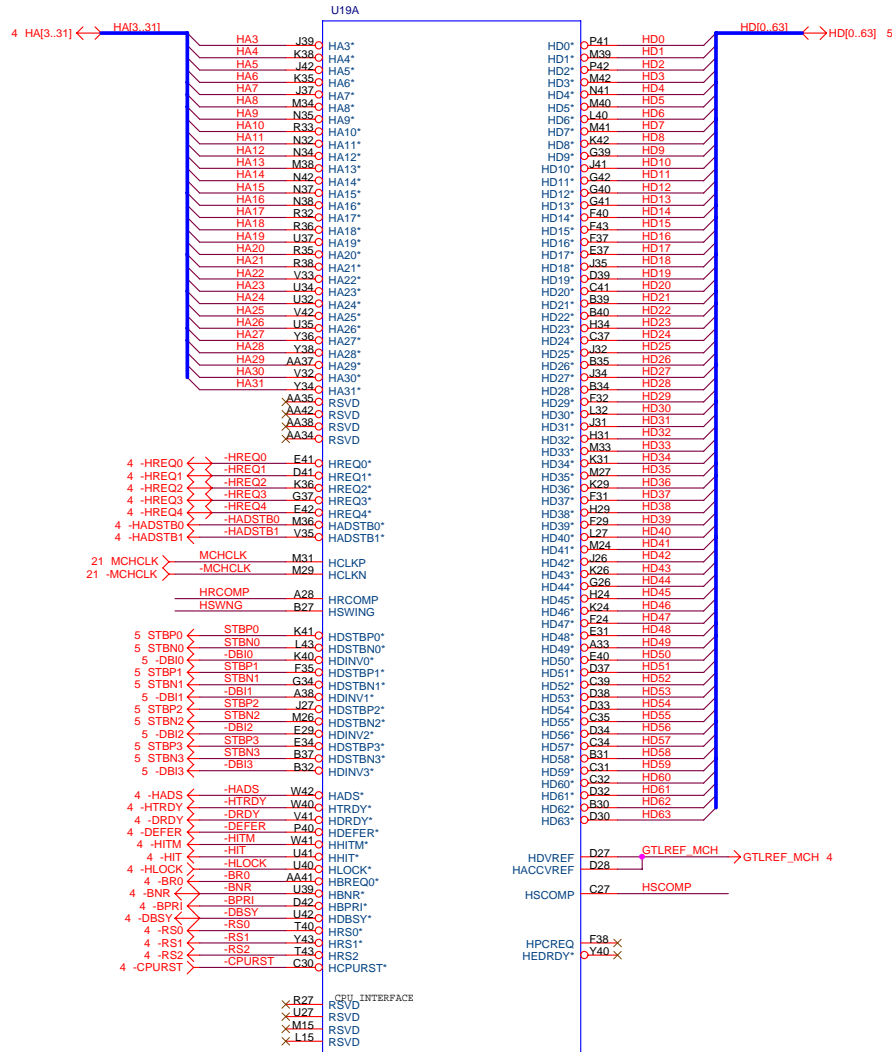

10HB1-033000-11-REV:A1
 10HB1-033000-21-REV:A2 FOR ACER

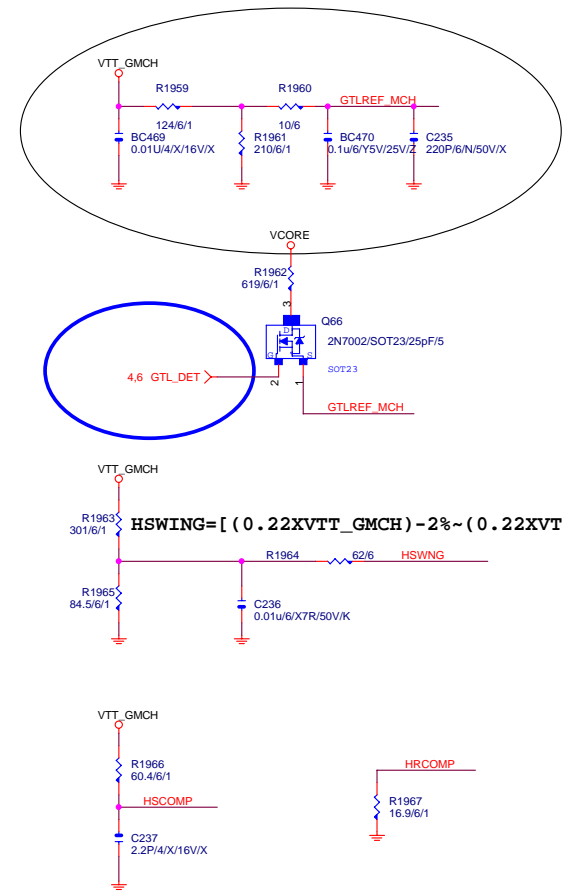

GIGABYTE TECHNOLOGIES, I		
Title GMCH-HOST		
Size Custom	Document Number 945P-S3	Rev 1.01
Date: Wednesday, August 02, 2006	Sheet 8	of 40

100歐姆:[20/5/7/5/20]

100歐姆:[20/5/7/5/20]

21 SRCLK_MCH
21 -SRCLK_MCH

100歐姆:[20/5/7/5/20]

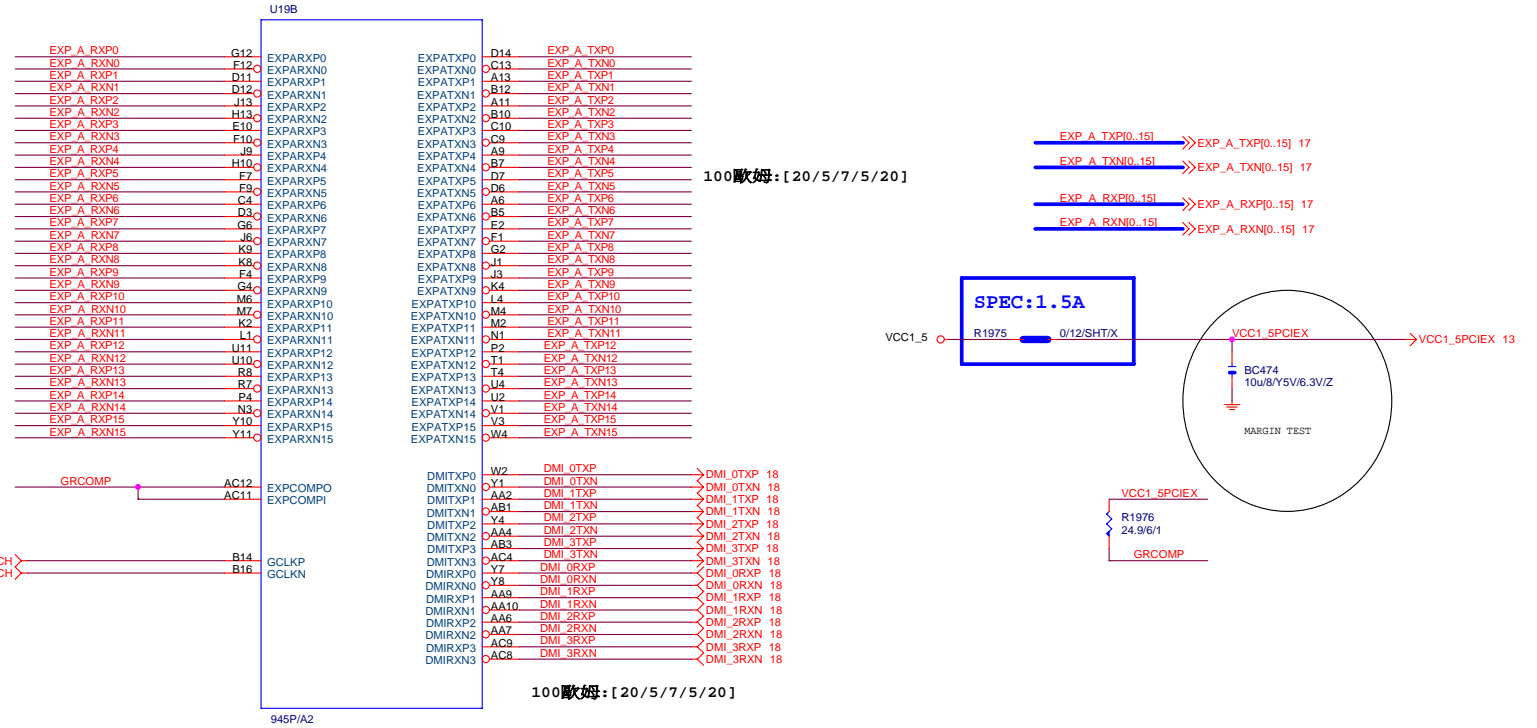

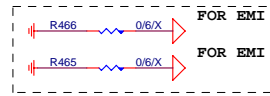
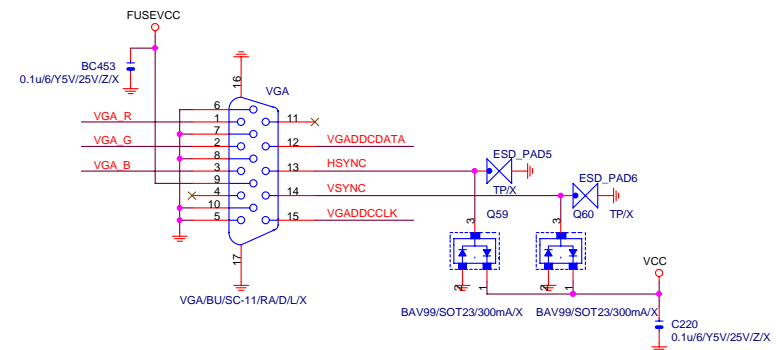
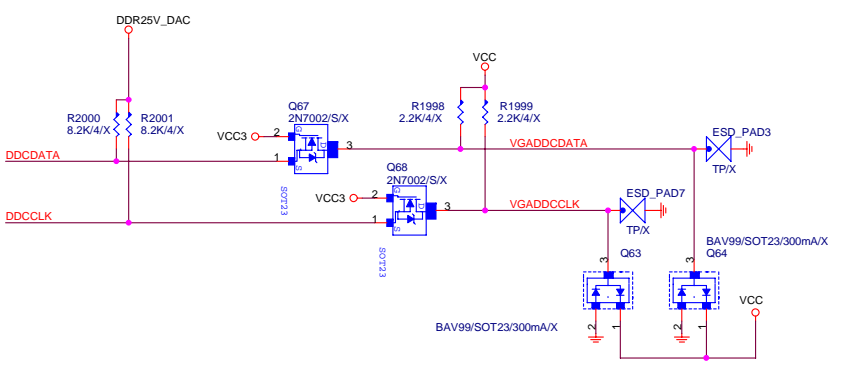
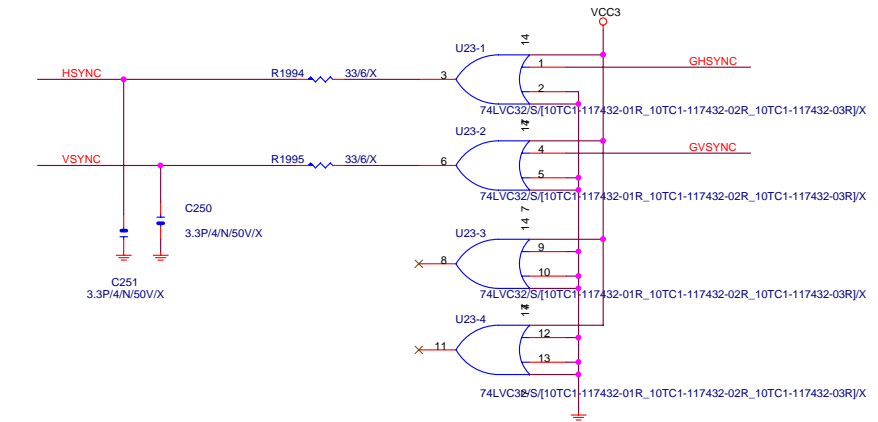
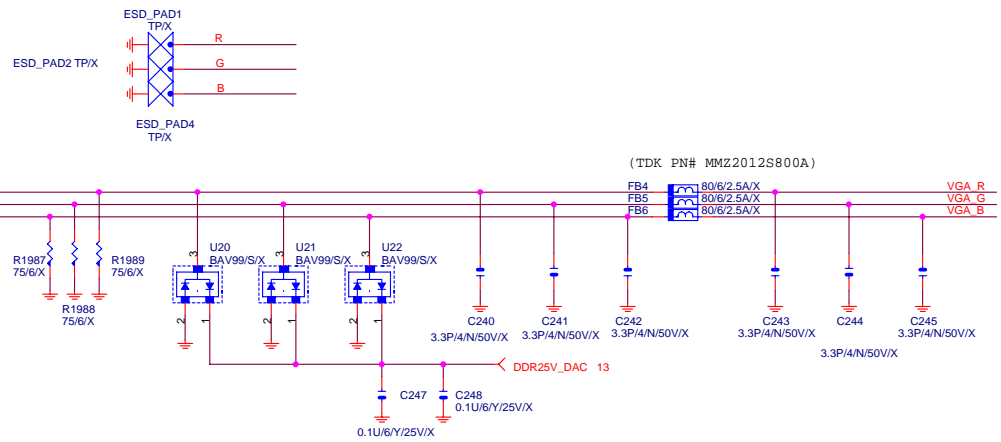
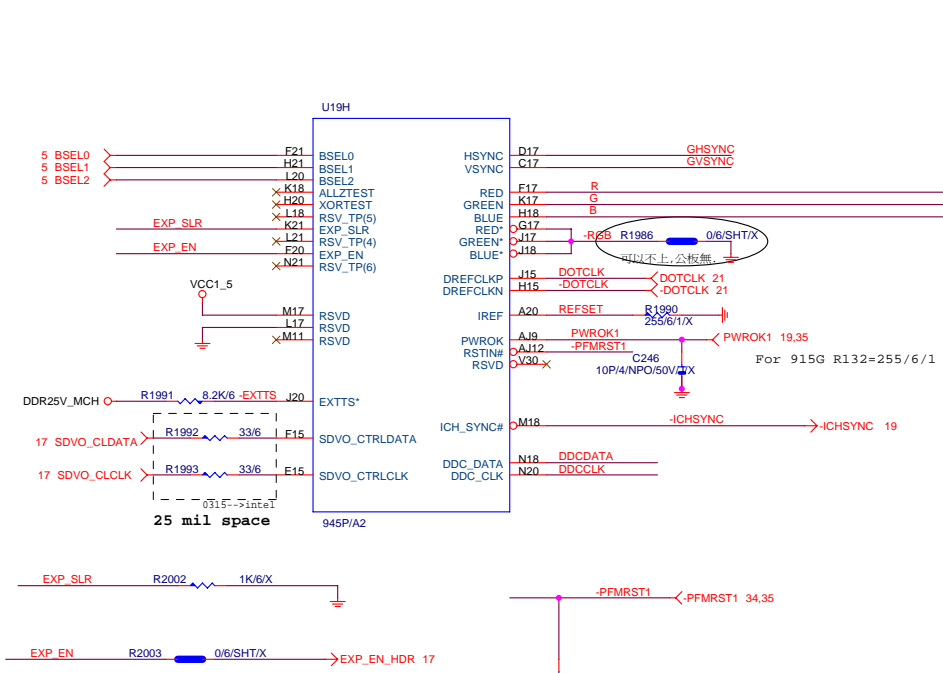

GIGABYTE THCHNOLOGIES, I

Title			GMCH-INTERNAL VGA		
Size	Document Number	945P-S3			Rev
Custom					1.01
Date:	Wednesday, August 02, 2006	Sheet	11	of	40

U19C

A4	VSS	N2
A16	VSS	N6
A22	VSS	N8
A26	VSS	N13
A31	VSS	N15
A35	VSS	N16
B4	VSS	N27
B6	VSS	N29
B9	VSS	N31
B11	VSS	N33
B13	VSS	N36
B21	VSS	N39
B22	VSS	N43
B28	VSS	P3
B33	VSS	P14
B38	VSS	P15
C3	VSS	P24
C5	VSS	P26
C7	VSS	P27
C12	VSS	P29
C14	VSS	P30
C22	VSS	R6
C40	VSS	R9
D2	VSS	R12
D5	VSS	R14
D10	VSS	R30
D16	VSS	R31
D20	VSS	R34
D21	VSS	R37
E3	VSS	R39
E4	VSS	T2
E7	VSS	T42
E9	VSS	U3
E12	VSS	U5
E13	VSS	U8
E17	VSS	U12
E18	VSS	U14
E20	VSS	U31
E21	VSS	U33
E32	VSS	U36
F2	VSS	U38
F6	VSS	V2
F13	VSS	V8
F18	VSS	V11
F26	VSS	V12
F34	VSS	V14
F42	VSS	V34
G3	VSS	V36
G5	VSS	V37
G7	VSS	V38
G9	VSS	V39
G10	VSS	V43
G13	VSS	W3
G15	VSS	Y2
G18	VSS	Y5
G20	VSS	Y6
G21	VSS	Y9
G24	VSS	Y12
G27	VSS	Y14
G29	VSS	Y31
G31	VSS	Y35
G32	VSS	Y37
G35	VSS	Y39
G38	VSS	Y42
H12	VSS	AA3
H17	VSS	AA6
H26	VSS	AA11
H27	VSS	AA12
H32	VSS	AA14
I2	VSS	AA21
J5	VSS	AA23
J7	VSS	AA31
J10	VSS	AA33
J12	VSS	AA36
J21	VSS	AB2
J24	VSS	AB43
J29	VSS	AC2
J38	VSS	AC3
J43	VSS	AC7
K3	VSS	AC10
K5	VSS	AC14
K6	VSS	AC21
K7	VSS	AC23
K10	VSS	AC31
K12	VSS	AC36
K13	VSS	AC37
K15	VSS	AC38
K20	VSS	AC39
K27	VSS	
K32	VSS	
K34	VSS	
K37	VSS	
K39	VSS	
L2	VSS	
L12	VSS	
L24	VSS	
L26	VSS	
L29	VSS	
L31	VSS	
L42	VSS	
M3	VSS	
M5	VSS	
M8	VSS	
M9	VSS	
M10	VSS	
M13	VSS	
M20	VSS	
M21	VSS	
M35	VSS	
M37	VSS	

945P/A2

U19E

AD7	VSS	AD7
AD9	VSS	AD9
AD11	VSS	AD11
AD13	VSS	AD13
AD33	VSS	AD33
N24	VSS	N24
AD37	VSS	AD37
AD42	VSS	AD42
N29	VSS	N29
AF1	VSS	AF1
AF2	VSS	AF2
N33	VSS	N33
AF5	VSS	AF5
N39	VSS	N39
AF36	VSS	AF36
P3	VSS	P3
P14	VSS	P14
P15	VSS	P15
P24	VSS	P24
P26	VSS	P26
P27	VSS	P27
AG37	VSS	AG37
P30	VSS	P30
AG38	VSS	AG38
AG39	VSS	AG39
AM42	VSS	AM42
A17	VSS	A17
A10	VSS	A10
A30	VSS	A30
A31	VSS	A31
A33	VSS	A33
A35	VSS	A35
A37	VSS	A37
T2	VSS	T2
AK26	VSS	AK26
AK29	VSS	AK29
U8	VSS	U8
AL1	VSS	AL1
AL2	VSS	AL2
AL3	VSS	AL3
AL7	VSS	AL7
U33	VSS	U33
AL12	VSS	AL12
AL13	VSS	AL13
AL15	VSS	AL15
AL18	VSS	AL18
AL21	VSS	AL21
AL23	VSS	AL23
AL24	VSS	AL24
U34	VSS	U34
AL32	VSS	AL32
AL33	VSS	AL33
V38	VSS	V38
AL37	VSS	AL37
B43	VSS	B43
AM5	VSS	AM5
W3	VSS	W3
Y2	VSS	Y2
AM33	VSS	AM33
AM36	VSS	AM36
AM37	VSS	AM37
AM39	VSS	AM39
AN2	VSS	AN2
AN4	VSS	AN4
AN13	VSS	AN13
Y37	VSS	Y37
AN17	VSS	AN17
AN18	VSS	AN18
AN20	VSS	AN20
AN21	VSS	AN21
AN23	VSS	AN23
AN24	VSS	AN24
AN26	VSS	AN26
AN27	VSS	AN27
AN31	VSS	AN31
AN42	VSS	AN42
AP5	VSS	AP5
AP7	VSS	AP7
AP10	VSS	AP10
AP12	VSS	AP12
AP29	VSS	AP29
AP34	VSS	AP34
AP38	VSS	AP38
AR1	VSS	AR1
AR6	VSS	AR6
AR15	VSS	AR15
AR20	VSS	AR20
AR24	VSS	AR24
AR32	VSS	AR32
AR37	VSS	AR37
AR39	VSS	AR39
AR43	VSS	AR43
AT12	VSS	AT12
AT17	VSS	AT17
AT18	VSS	AT18
AT21	VSS	AT21
AT23	VSS	AT23
AT26	VSS	AT26
AT27	VSS	AT27
AT31	VSS	AT31
AU6	VSS	AU6
AU9	VSS	AU9
AU12	VSS	AU12
AU13	VSS	AU13
AU15	VSS	AU15
AU17	VSS	AU17
AU20	VSS	AU20
AD18	VSS	AD18
AD20	VSS	AD20
AD22	VSS	AD22
AD24	VSS	AD24
AD27	VSS	AD27
AD29	VSS	AD29
AE19	VSS	AE19
AE21	VSS	AE21
AE23	VSS	AE23
AE25	VSS	AE25
AF18	VSS	AF18
AF20	VSS	AF20
AF22	VSS	AF22
AF24	VSS	AF24
AY1	VSS	AY1
BC4	VSS	BC4

VSS	AU21
VSS	AU24
VSS	AU26
VSS	AU29
VSS	AU32
VSS	AU34
VSS	AV2
VSS	AV10
VSS	AV17
VSS	AV37
VSS	AW10
VSS	BA4
VSS	BA42
VSS	BB3
VSS	BB6
VSS	BB11
VSS	BB14
VSS	BB19
VSS	BB34
VSS	BB39
VSS	BB41
VSS	BC9
VSS	A40
VSS	D1
VSS	D43
VSS	R26
VSS	R29
VSS	U29
VSS	V24
VSS	V26
VSS	V29
VSS	W21
VSS	W23
VSS	W25
VSS	Y20
VSS	Y22
VSS	Y24
VSS	Y26
VSS	Y29
VSS	AA27
VSS	AA29
VSS	AC19
VSS	AC25
VSS	AC29
NC	AA2
NC	B2
NC	B3
NC	B4
NC	B42
NC	B43
NC	C2
NC	C4
NC	E35
NC	AV26
NC	AV27
NC	AW2
NC	AW28
NC	BA2
NC	BB1
NC	BB2
NC	BB43
NC	BC1
NC	BC2
NC	BC42
NC	BC43
RSVD	AK21
RSVD	AJ23
RSVD	AJ26
RSVD	AL25
RSVD	AL20
RSVD	AJ21
RSVD	AL26
RSVD	AK27
RSVD	AD30
RSVD	AC34
RSVD	Y30
RSVD	Y32
RSVD	AF31
RSVD	AD31
RSVD	U30
RSVD	V31
RSVD	AA30
RSVD	AC30
RSVD	AA3
RSVD	AG26
RSVD	AG27
RSVD	AJ24
RSVD	AJ27
RSVD	AK40
RSVD	AW12
RSVD	AW18
RSVD	AY14
RSVD	BC16
RSVD	AJ29
RSVD	AG29

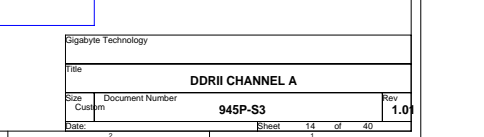
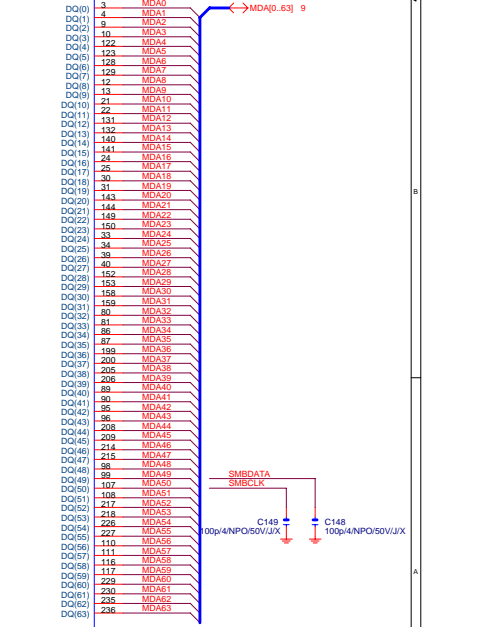
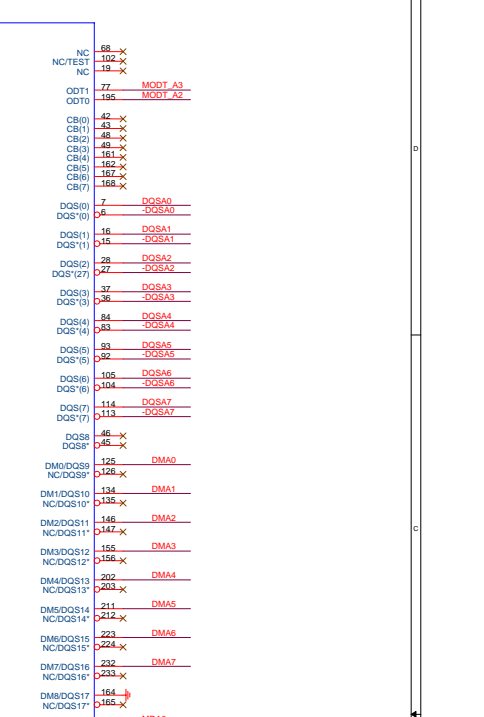
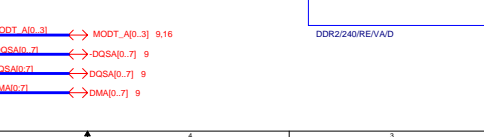
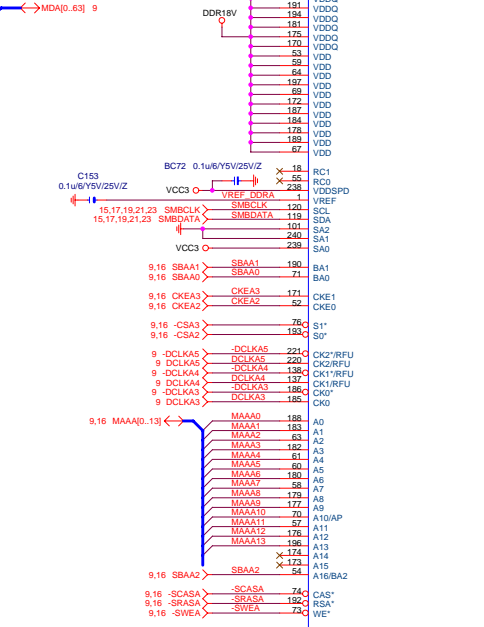
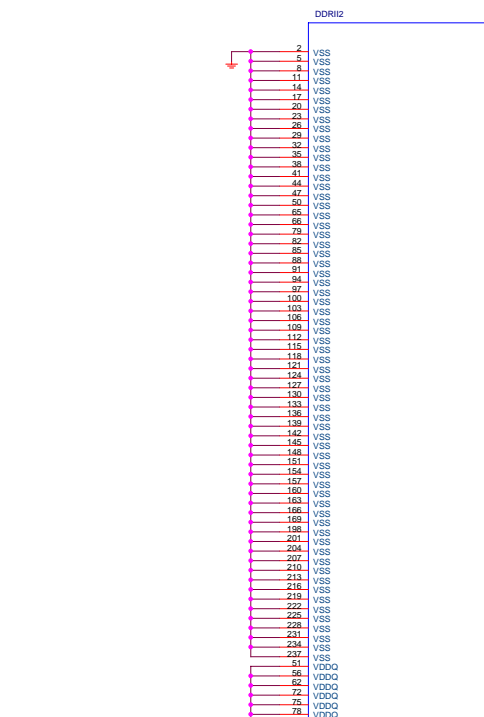
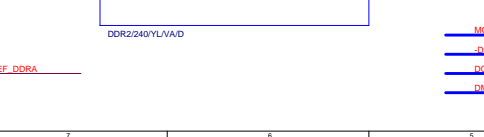
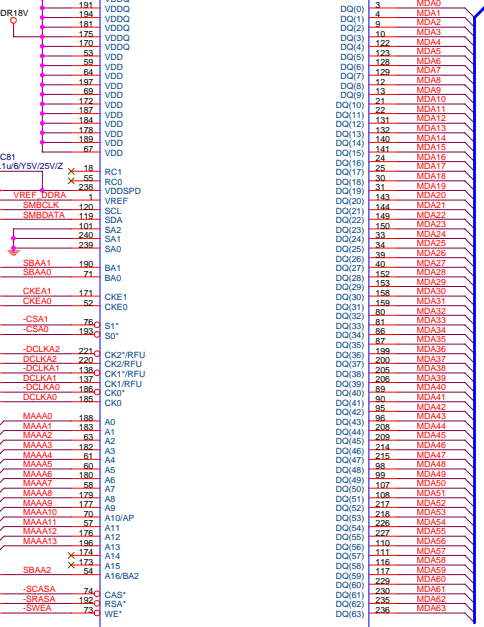
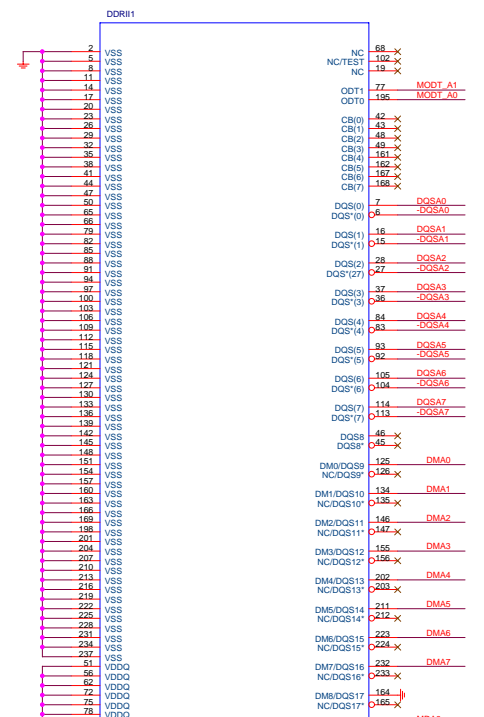

Sigabyte Technology	
Title	DDR2 CHANNEL A
Size	Document Number
Customer	945P-S3
Date	Rev 1.0

DDR TERMINATION CHANNEL A

DDRVTT Decouple

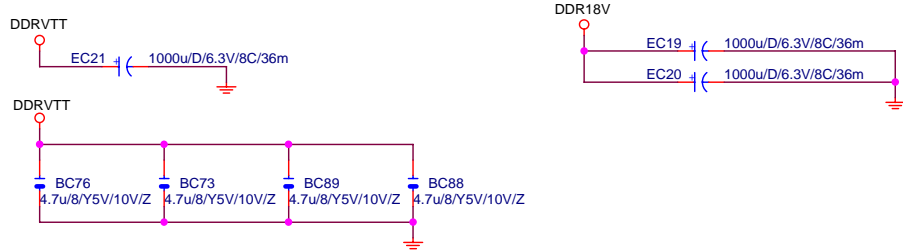

DDR18V Decouple

DDRVTT Decouple

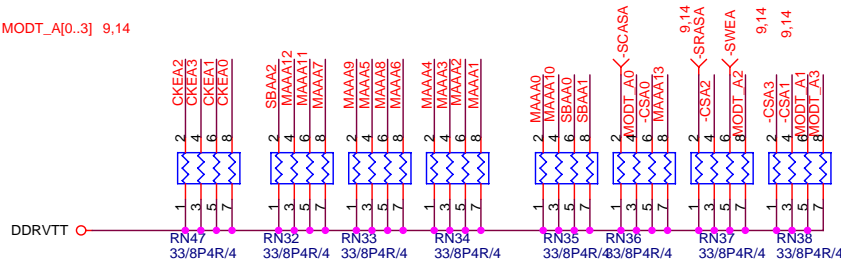
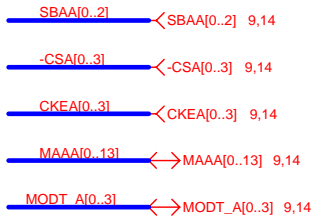
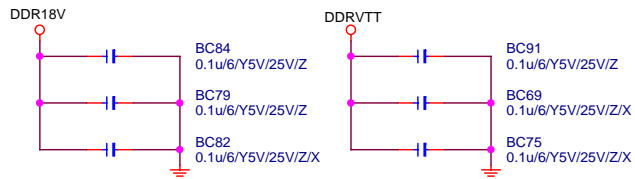

DDR TERMINATION CHANNEL B

DDR18V Decouple

DDRVTT Decouple

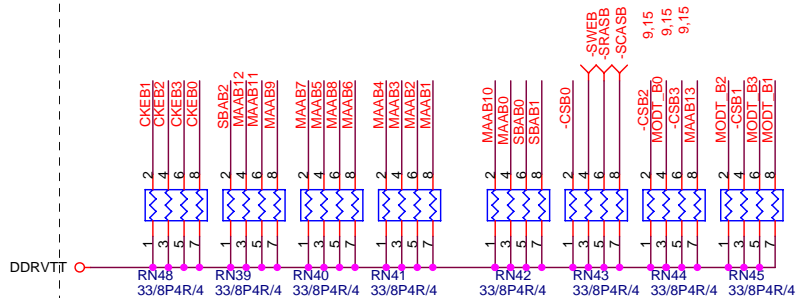
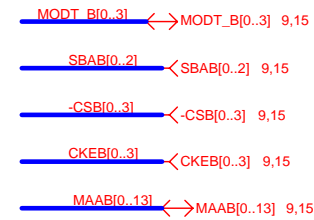
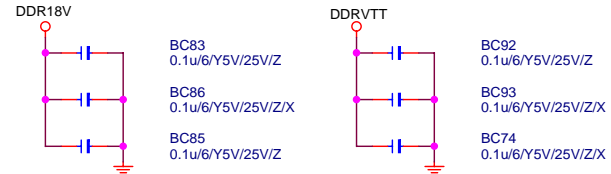

Gigabyte Technology

Title		
DDRII TERMINATOR		
Size Custom	Document Number	Rev
	945P-S3	1.01
Date:	Wednesday, August 02, 2006	Sheet 16 of 40

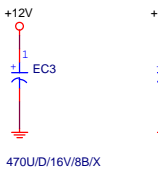
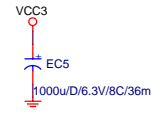

EXP_A_TXP[0..15] >> EXP_A_TXP[0..15] 10
 EXP_A_TXN[0..15] >> EXP_A_TXN[0..15] 10

EXP_A_TXP0	C27	0.1u4/Y5V/16V/Z	EXP_A_TXP0C
EXP_A_TXN0	C26	0.1u4/Y5V/16V/Z	EXP_A_TXN0C
EXP_A_TXP1	C31	0.1u4/Y5V/16V/Z	EXP_A_TXP1C
EXP_A_TXN1	C32	0.1u4/Y5V/16V/Z	EXP_A_TXN1C
EXP_A_TXP2	C34	0.1u4/Y5V/16V/Z	EXP_A_TXP2C
EXP_A_TXN2	C37	0.1u4/Y5V/16V/Z	EXP_A_TXN2C
EXP_A_TXP3	C38	0.1u4/Y5V/16V/Z	EXP_A_TXP3C
EXP_A_TXN3	C39	0.1u4/Y5V/16V/Z	EXP_A_TXN3C
EXP_A_TXP4	C40	0.1u4/Y5V/16V/Z	EXP_A_TXP4C
EXP_A_TXN4	C41	0.1u4/Y5V/16V/Z	EXP_A_TXN4C
EXP_A_TXP5	C48	0.1u4/Y5V/16V/Z	EXP_A_TXP5C
EXP_A_TXN5	C47	0.1u4/Y5V/16V/Z	EXP_A_TXN5C
EXP_A_TXP6	C52	0.1u4/Y5V/16V/Z	EXP_A_TXP6C
EXP_A_TXN6	C49	0.1u4/Y5V/16V/Z	EXP_A_TXN6C
EXP_A_TXP7	C63	0.1u4/Y5V/16V/Z	EXP_A_TXP7C
EXP_A_TXN7	C62	0.1u4/Y5V/16V/Z	EXP_A_TXN7C
EXP_A_TXP8	C65	0.1u4/Y5V/16V/Z	EXP_A_TXP8C
EXP_A_TXN8	C66	0.1u4/Y5V/16V/Z	EXP_A_TXN8C
EXP_A_TXP9	C67	0.1u4/Y5V/16V/Z	EXP_A_TXP9C
EXP_A_TXN9	C70	0.1u4/Y5V/16V/Z	EXP_A_TXN9C
EXP_A_TXP10	C81	0.1u4/Y5V/16V/Z	EXP_A_TXP10C
EXP_A_TXN10	C80	0.1u4/Y5V/16V/Z	EXP_A_TXN10C
EXP_A_TXP11	C84	0.1u4/Y5V/16V/Z	EXP_A_TXP11C
EXP_A_TXN11	C83	0.1u4/Y5V/16V/Z	EXP_A_TXN11C
EXP_A_TXP12	C86	0.1u4/Y5V/16V/Z	EXP_A_TXP12C
EXP_A_TXN12	C85	0.1u4/Y5V/16V/Z	EXP_A_TXN12C
EXP_A_TXP13	C92	0.1u4/Y5V/16V/Z	EXP_A_TXP13C
EXP_A_TXN13	C91	0.1u4/Y5V/16V/Z	EXP_A_TXN13C
EXP_A_TXP14	C99	0.1u4/Y5V/16V/Z	EXP_A_TXP14C
EXP_A_TXN14	C97	0.1u4/Y5V/16V/Z	EXP_A_TXN14C
EXP_A_TXP15	C106	0.1u4/Y5V/16V/Z	EXP_A_TXP15C
EXP_A_TXN15	C104	0.1u4/Y5V/16V/Z	EXP_A_TXN15C

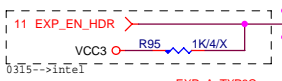
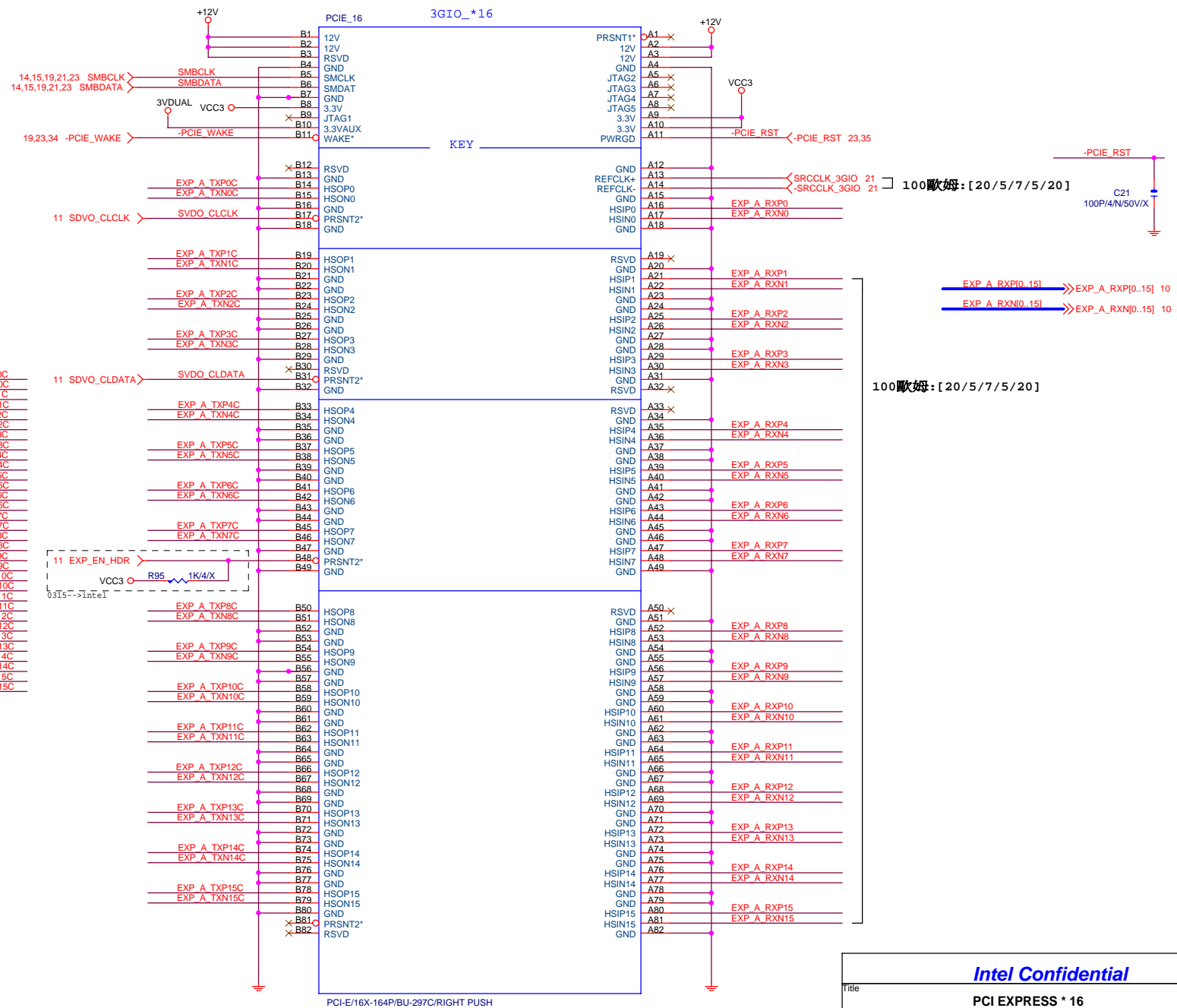

100歐姆: [20/5/7/5/20]

100歐姆: [20/5/7/5/20]

PCI-E/16X-164P/BU-297C/RIGHT PUSH

FOR ICH7R POWER ON 瞬間會HIGH 到1.8V 之後0V, 必須PULL DOWN 1K/6

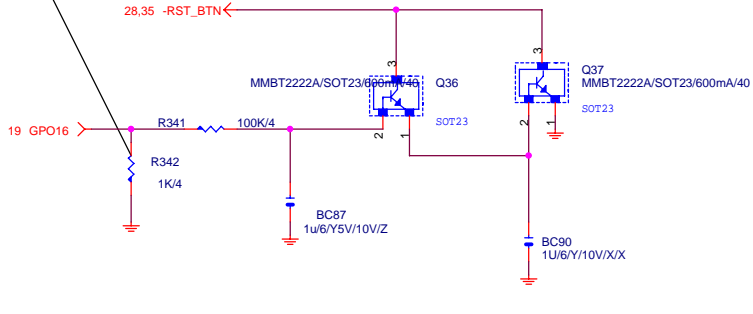

**H/W
RESET**

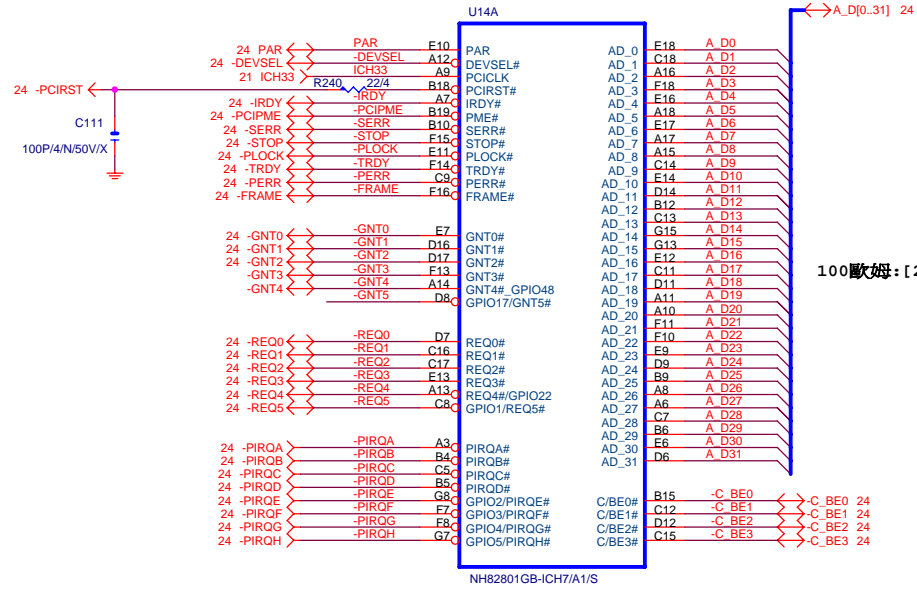

10HB1-032801-M1 REV:NON

	GNT4#	GNT5#
SPI=	1	0
PCI=	0	1
LPC=	1	1

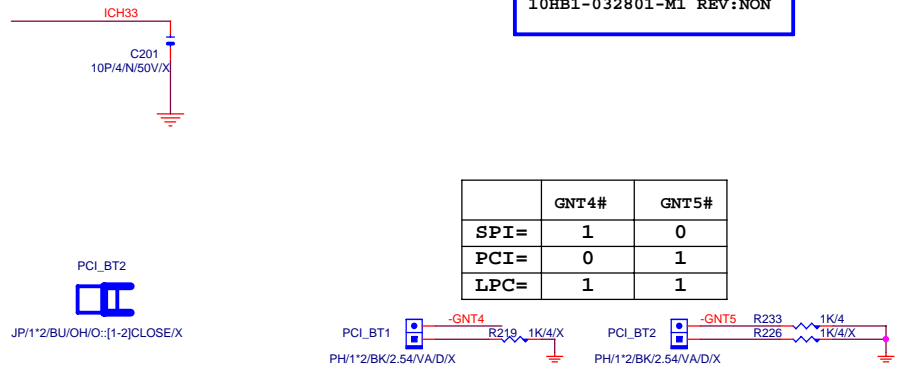

100歐姆:[20/5/7/5/20]

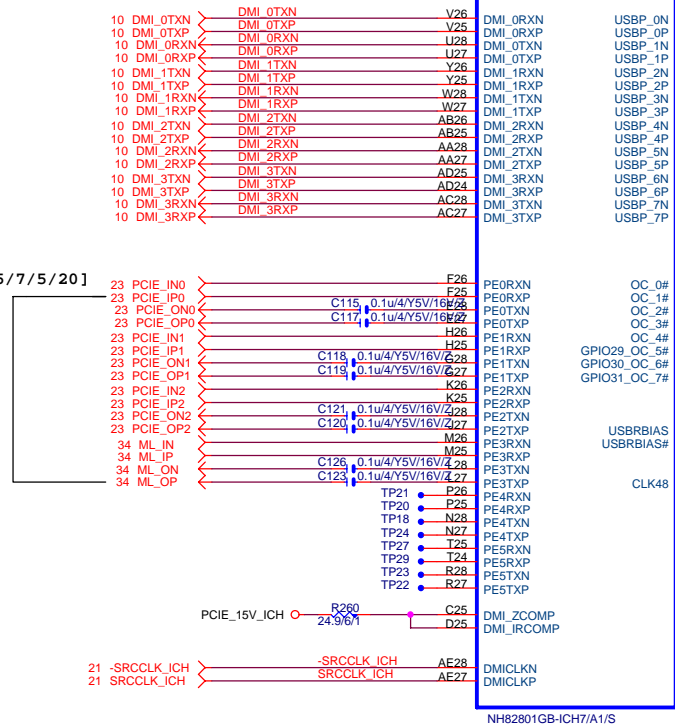

90歐姆:[20/7.5/7.5/7.5/20]

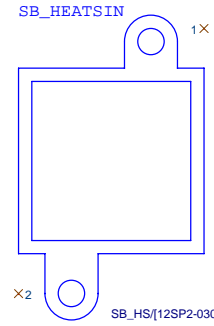
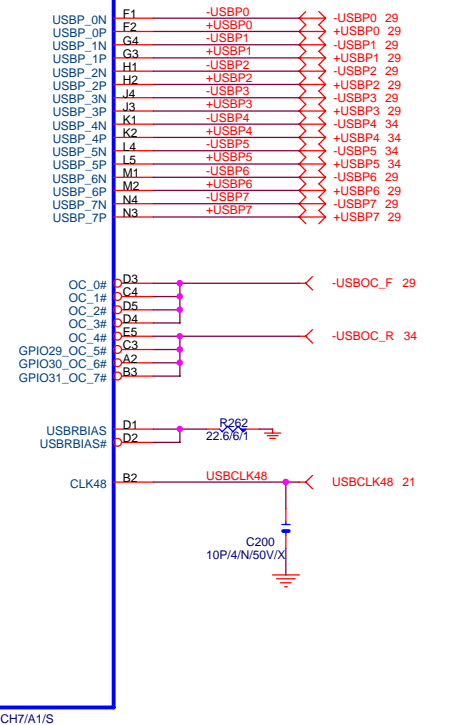

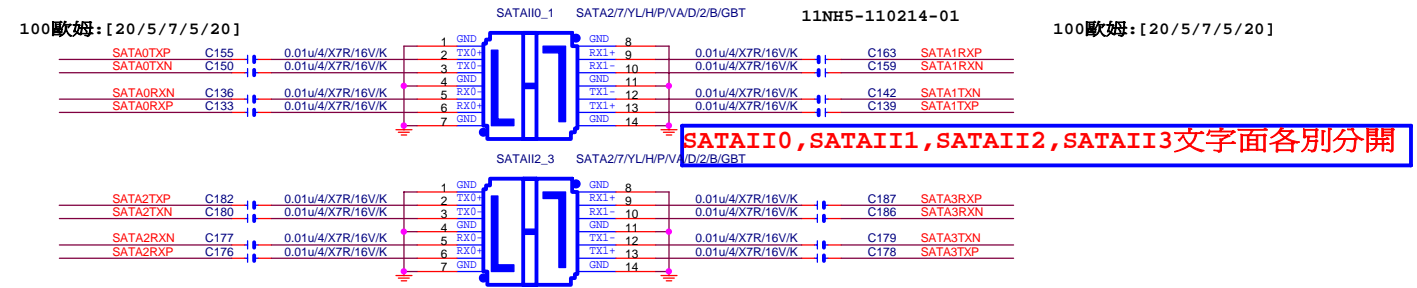
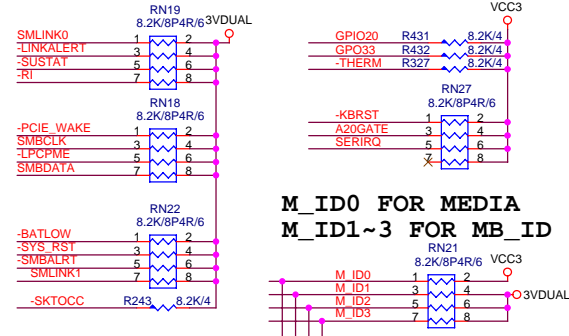
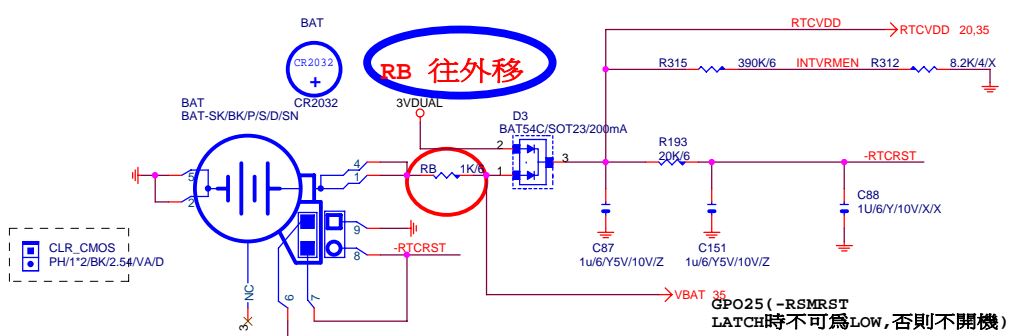
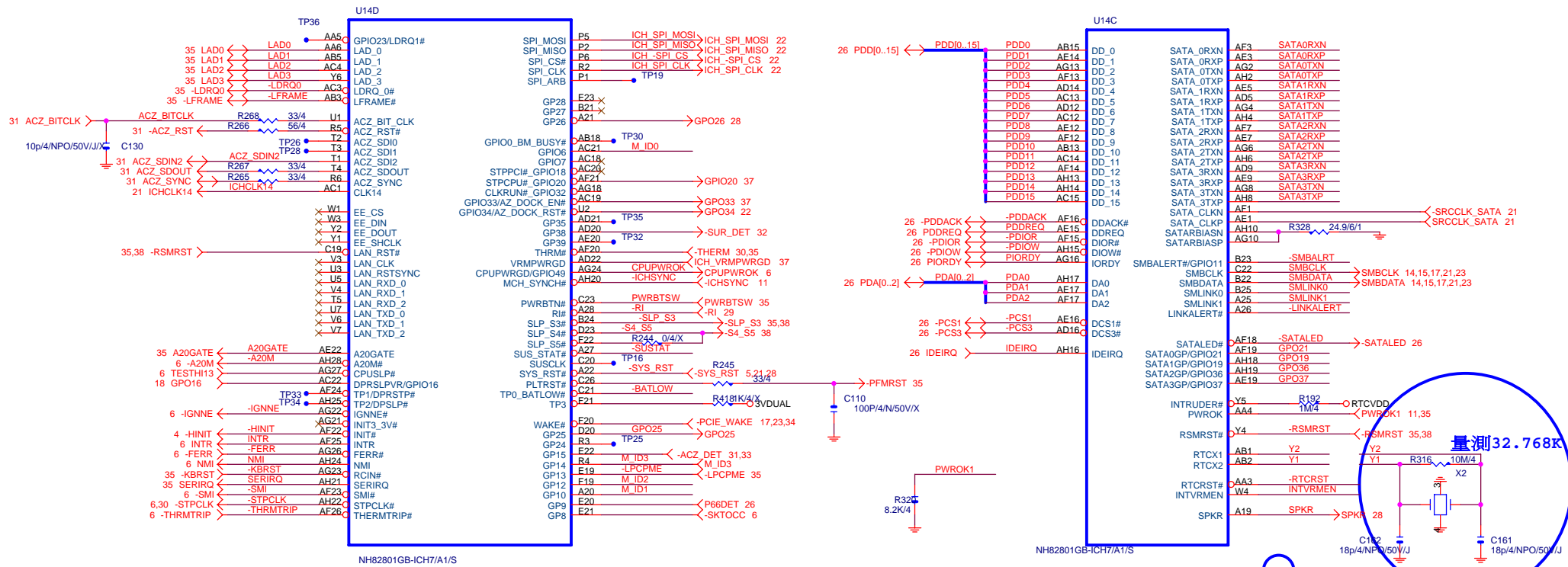

A4	VSS1	R14
A23	VSS2	R15
B1	VSS3	R16
B8	VSS4	R17
B11	VSS5	R18
B14	VSS6	T12
B17	VSS7	T13
B20	VSS8	T14
B26	VSS9	T15
B28	VSS10	T16
C2	VSS11	T17
C6	VSS12	U4
D10	VSS13	U12
D13	VSS14	U13
D18	VSS15	U14
D21	VSS16	U15
D24	VSS17	U16
E1	VSS18	U17
E2	VSS19	U24
E8	VSS20	U25
E15	VSS21	U26
F3	VSS22	U27
F4	VSS23	V13
F5	VSS24	V15
F12	VSS25	V24
F27	VSS26	V27
F28	VSS27	V28
G1	VSS28	W6
G2	VSS29	W24
G6	VSS30	W25
G9	VSS31	W26
G14	VSS32	Y3
G18	VSS33	Y24
G21	VSS34	Y27
G24	VSS35	Y28
G25	VSS36	AA1
G26	VSS37	AA24
H3	VSS38	AA25
H4	VSS39	AA26
H5	VSS40	AA4
H24	VSS41	AA6
H27	VSS42	AB11
H28	VSS43	AB14
J1	VSS44	AB16
J2	VSS45	AB19
J5	VSS46	AB21
J24	VSS47	AB24
J25	VSS48	AB27
J26	VSS49	AB28
K24	VSS50	AC2
K27	VSS51	AC5
K28	VSS52	AC9
L13	VSS53	AC11
L15	VSS54	AD1
L24	VSS55	AD3
L25	VSS56	AD4
L26	VSS57	AD7
M3	VSS58	AD8
M4	VSS59	AD11
M5	VSS60	AD15
M12	VSS61	AD19
M13	VSS62	AD23
M14	VSS63	AE2
M15	VSS64	AE4
M16	VSS65	AE8
M17	VSS66	AE11
M24	VSS67	AE13
M27	VSS68	AE18
M28	VSS69	AE21
N1	VSS70	AE24
N2	VSS71	AE25
N5	VSS72	AF2
N6	VSS73	AF4
N11	VSS74	AF8
N12	VSS75	AF11
N13	VSS76	AF11
N14	VSS77	AF27
N15	VSS78	AG1
N16	VSS79	AG3
N17	VSS80	AG7
N18	VSS81	AG7
N18	VSS82	AG14
N24	VSS83	AG17
N25	VSS84	AG20
N26	VSS85	AG25
P3	VSS86	AH1
P4	VSS87	AH3
P12	VSS88	AH7
P13	VSS89	AH12
P14	VSS90	AH23
P15	VSS91	AH27
P16	VSS92	C27
P17	VSS93	E4
P24	VSS94	E4
P27	VSS95	AG11
P28	VSS96	
R1	VSS97	
R11	VSS98	
R12	VSS99	
R13	VSS100	

NH82801GB-ICH7/A1/S

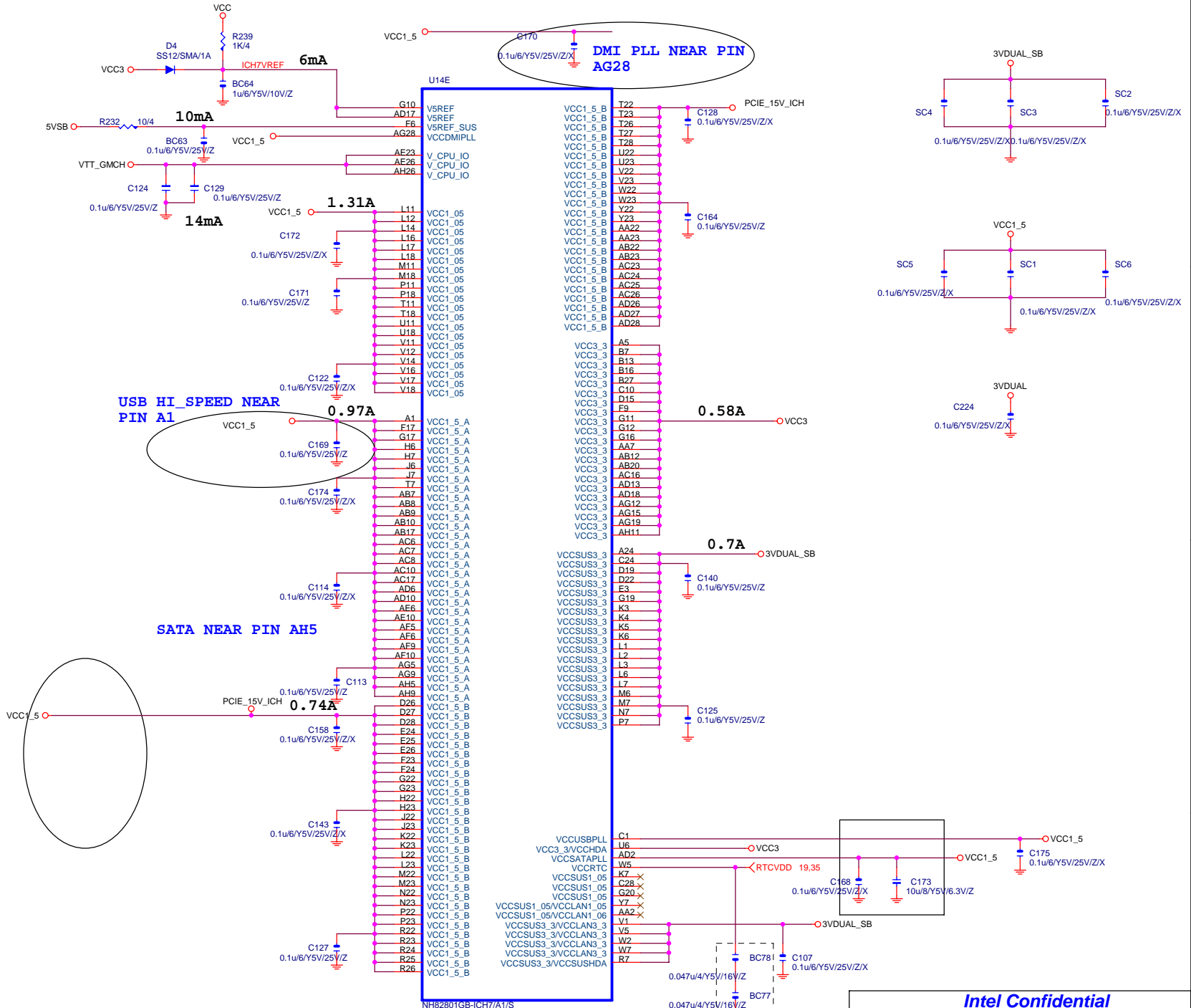

Intel Confidential		
Title ICH6-PWR & GND		
Size B	Document Number 945P-S3	Rev 1.01
Date: Wednesday, August 02, 2006	Sheet 20	of 40

GSEL=1, DOT FREQ=96MHZ
GSEL=0, DOT
FREQ=100MHZ

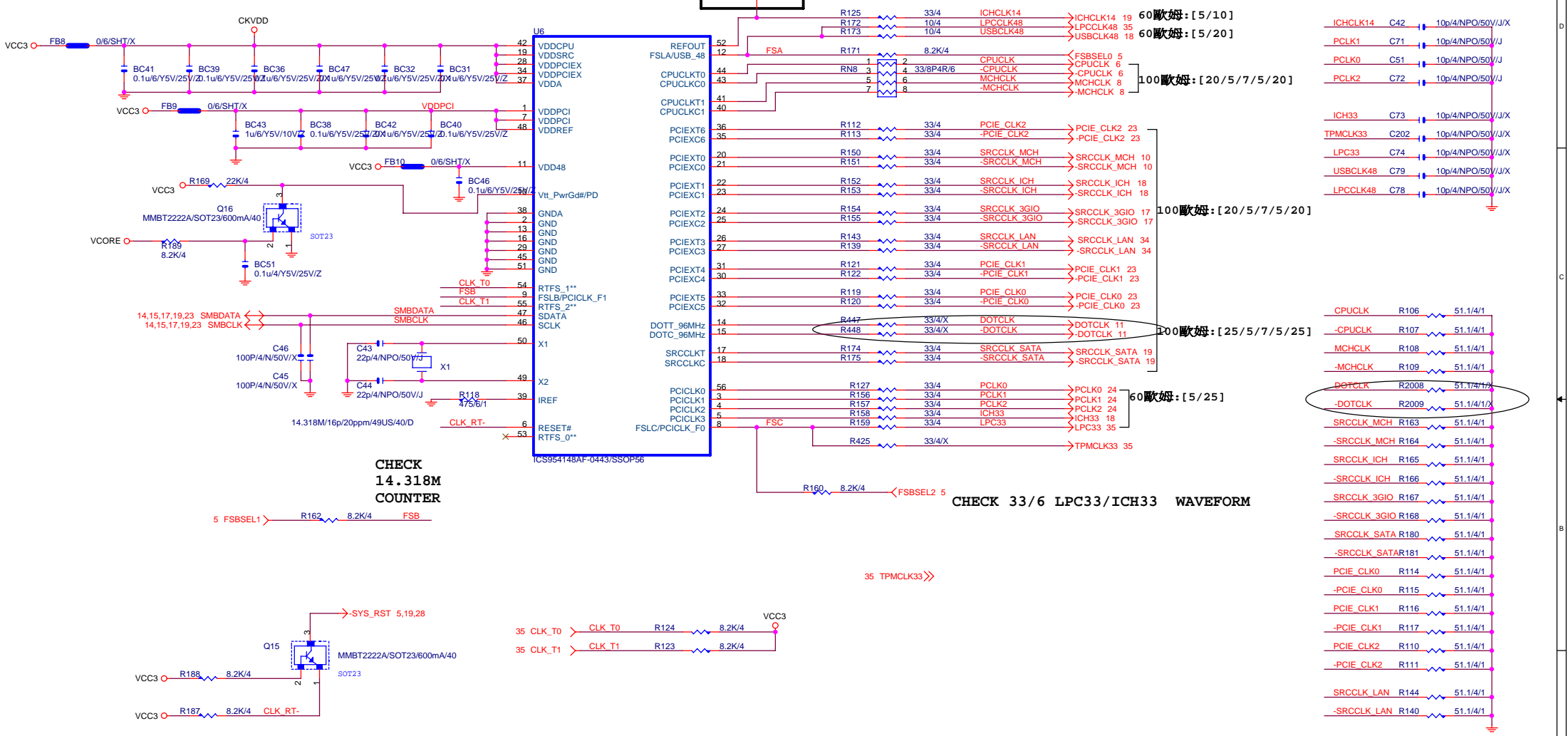

CHECK
14.318M
COUNTER

CHECK 33/6 LPC33/ICH33 WAVEFORM

Title			CK505 CLK GEN
Size	Document Number	945P-S3	
Custom		Rev	1.01
Date:	Wednesday, August 02, 2006	Sheet	21 of 40

ATX POWER CONNECTOR

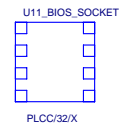
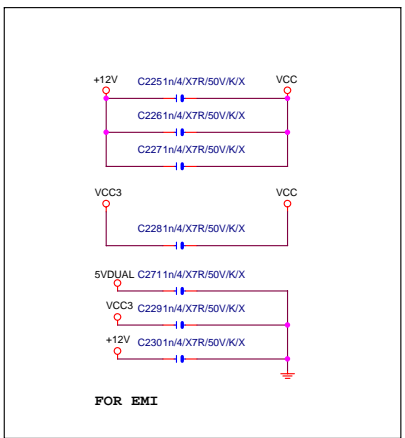
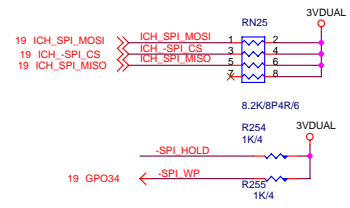
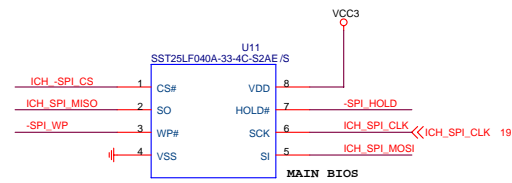
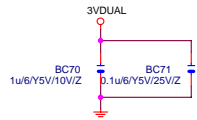
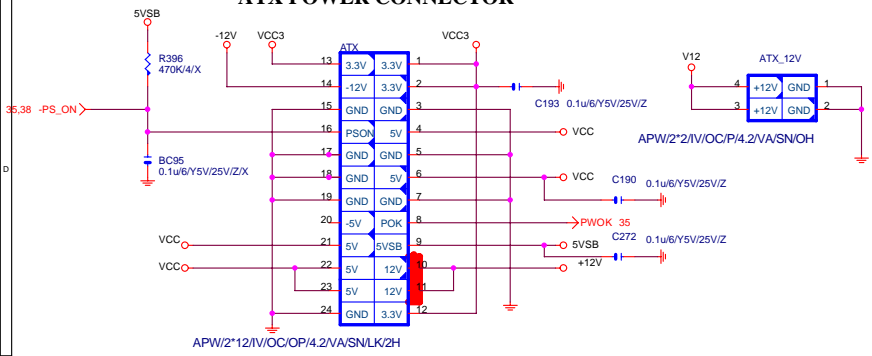

GIGABYTE			
Title ATX POWER CONNECTOR,DUAL BIOS			
Size Custom	Document Number 945P-S3	Rev 1.01	
Date: Wednesday, August 02, 2006	Sheet 2	of 22	40

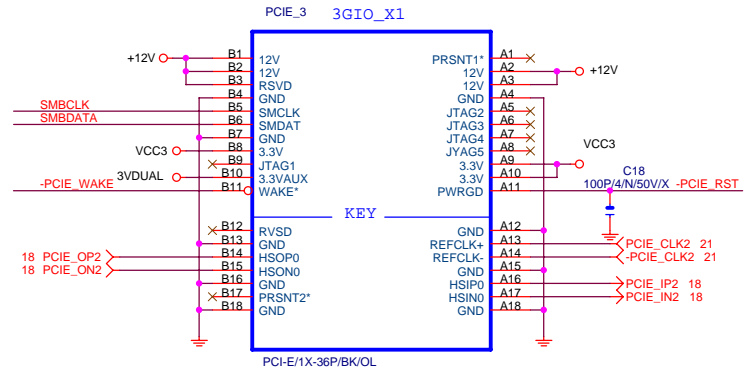
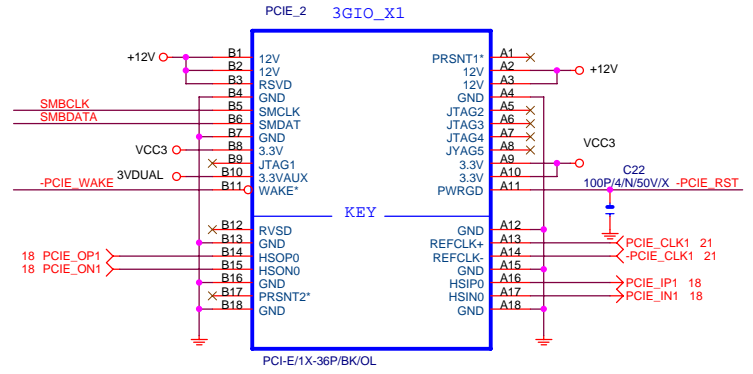
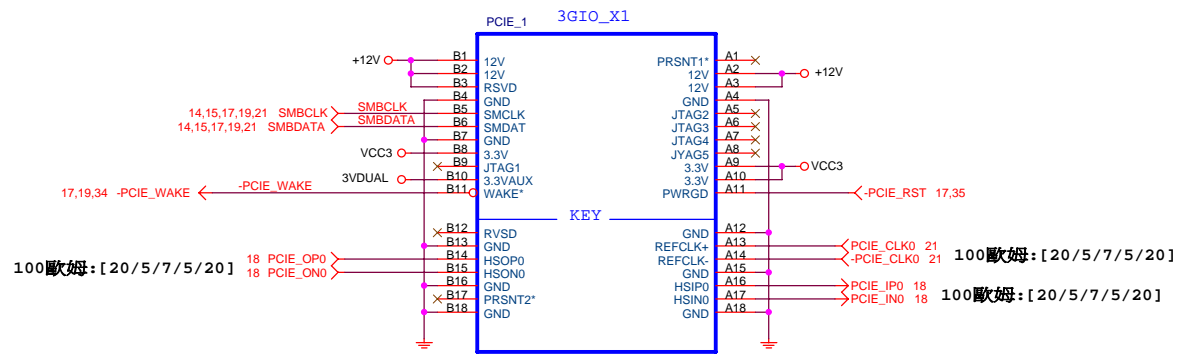

Intel Confidential		
Title		
PCI E SLOT 1, 2, 3		
Size	Document Number	Rev
B	945P-S3	1.01
Date:	Wednesday, August 02, 2006	Sheet 23 of 40
	2	1

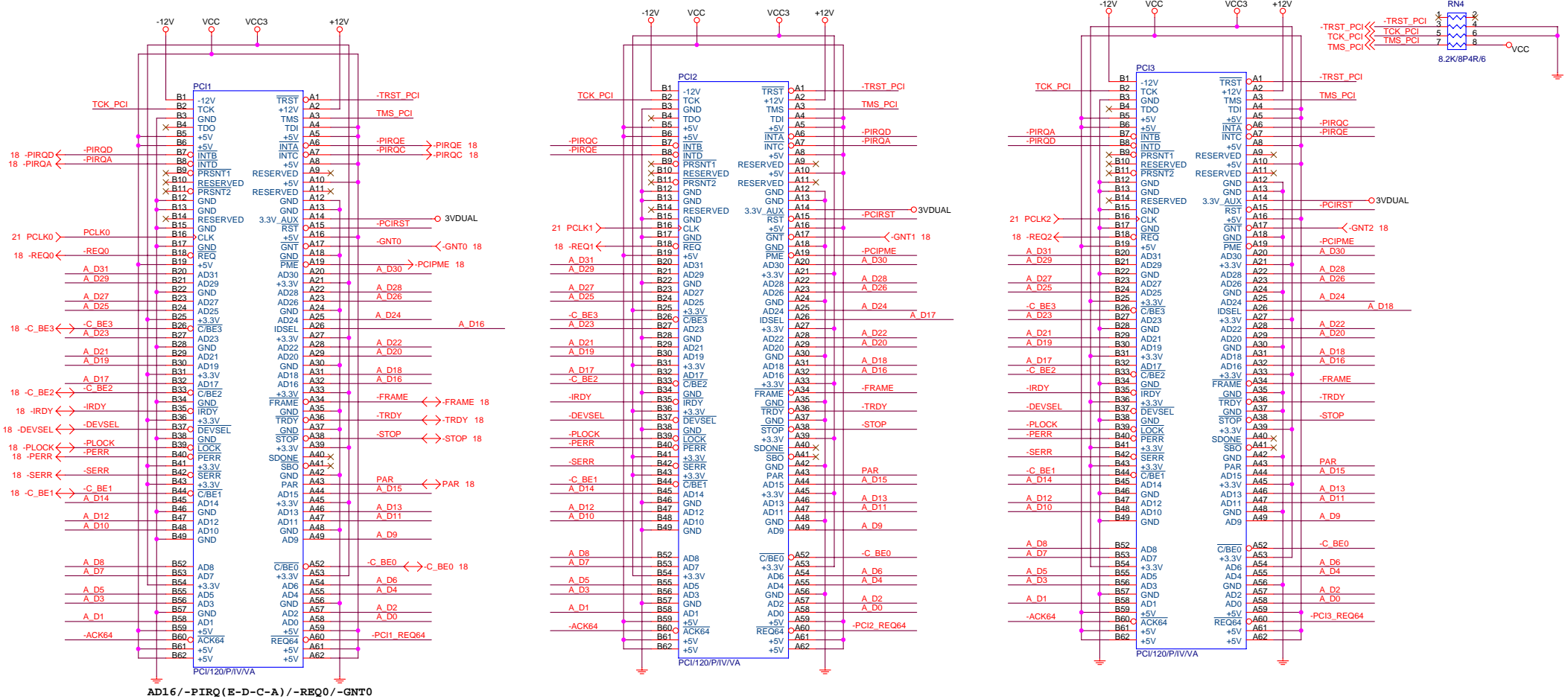

AD16/-PIRQ (E-D-C-A) / -REQ0 / -GNT0

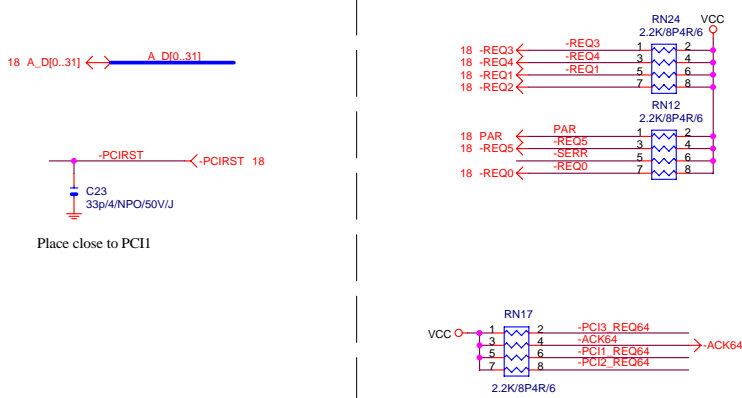

Place close to PCI1

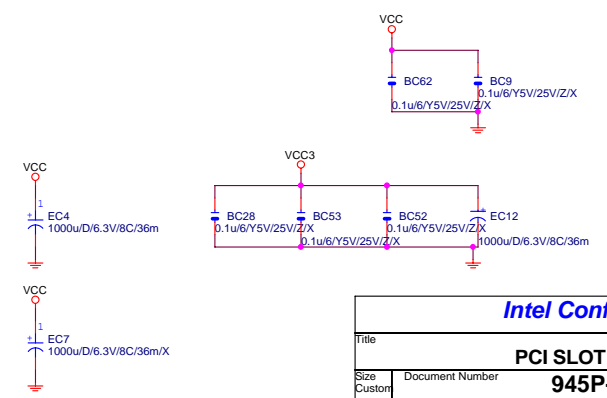
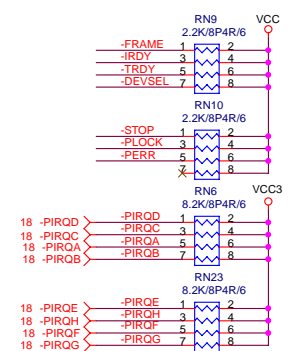

Intel Confidential	
PCI SLOT 1, 2	
Title	Rev 1.01
Document Number	945P-S3
Date:	Wednesday, August 02, 2006
Sheet	24 of 40

TEMP. SENSE

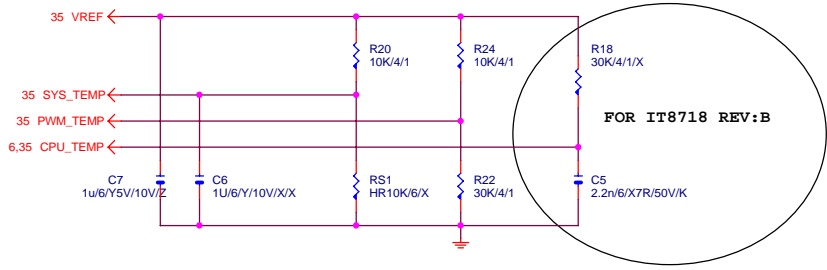

VOLTAGE SENSE

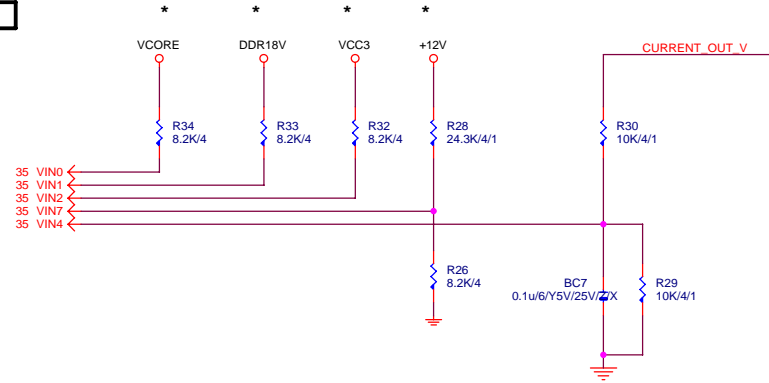

DUAL POWER

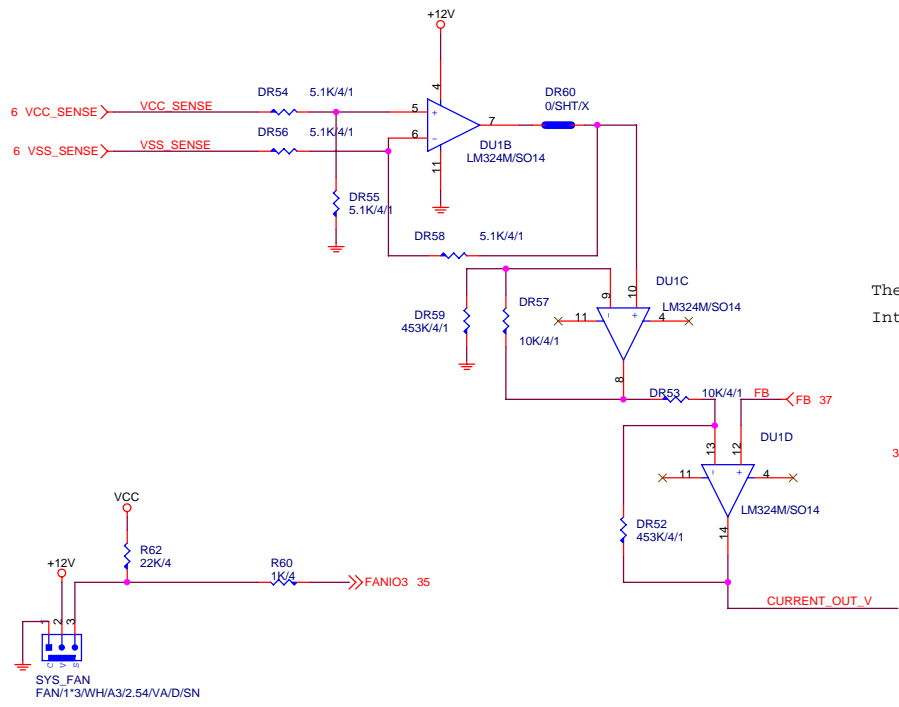

CPU/SYS FAN

If use PBSS5240 lpcs : (non airflow) If use PBSS5240 lpcs : (with airflow)

CPUFAN_VCC=12V: Temp=40 deg	CPUFAN_VCC=12V: Temp=33 deg
CPUFAN_VCC=11V: Temp=82 deg	CPUFAN_VCC=11V: Temp=62 deg
CPUFAN_VCC=10V: Temp=70 deg	CPUFAN_VCC=10V: Temp=86 deg
CPUFAN_VCC= 9V: Temp=110 deg	CPUFAN_VCC= 9V: Temp=117 deg
CPUFAN_VCC= 8V: Temp>200 deg	CPUFAN_VCC= 8V: Temp>122 deg

ThermalTake FAN Power Consumption: 0.82A
Intel FAN Power Consumption Spec: 1.1A

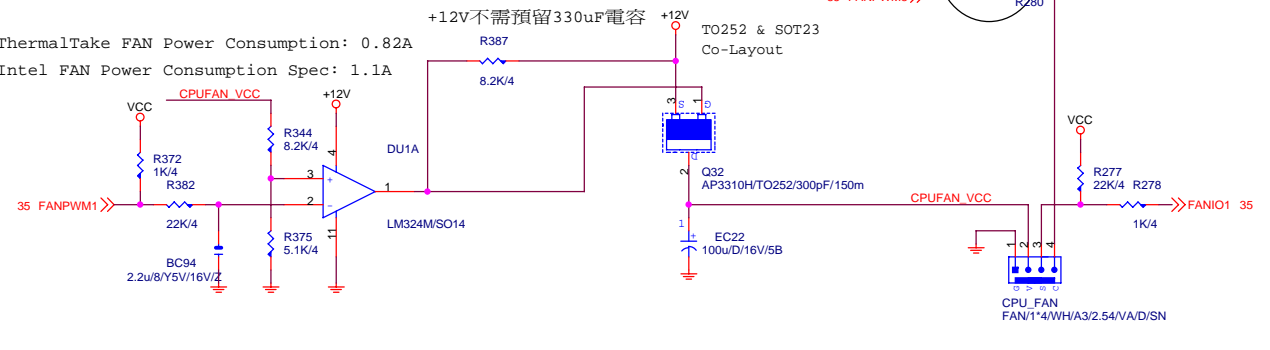

GIGABYTE

HWM/FANCI/BIOS

Title		Rev	
Document Number		1.01	
945P-S3			
Date:	Wednesday, August 02, 2006	Sheet	25 of 40

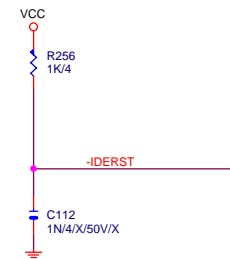
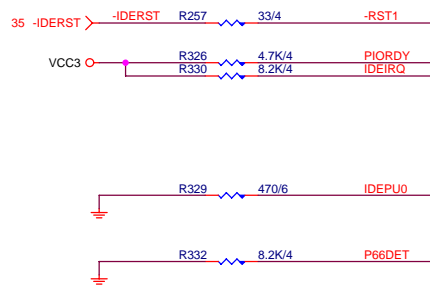
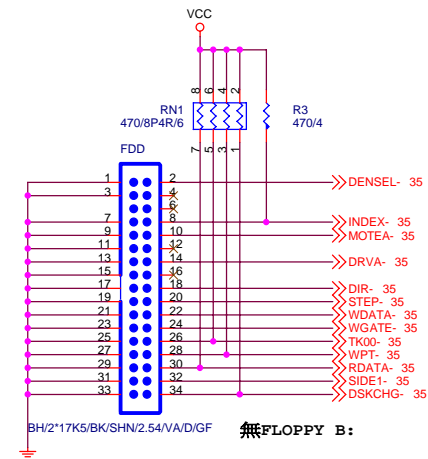
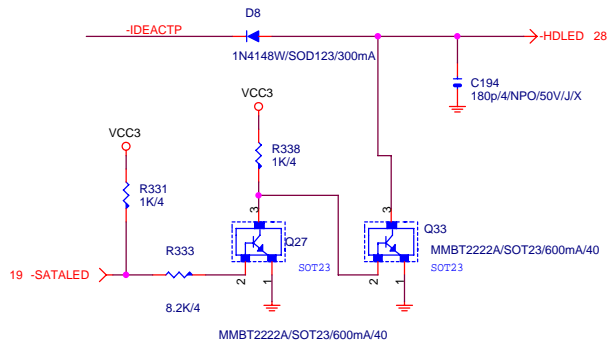

Default 不上,由IT8712 OUTPUT,REV0.2 驗證

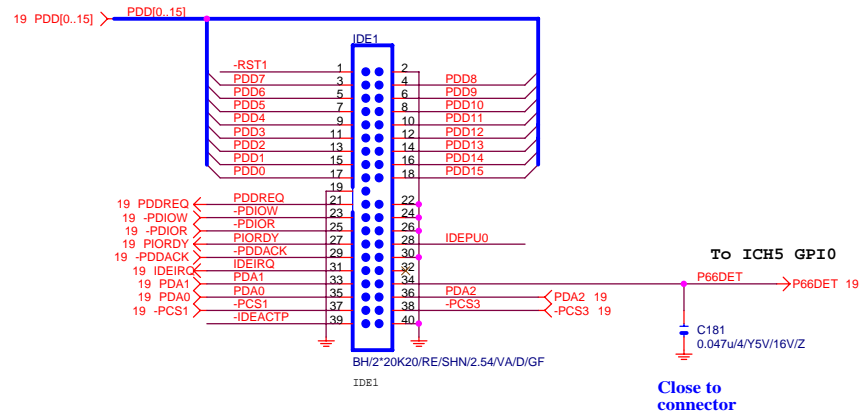

PRIMARY IDE CONNECTOR

Intel Confidential

Title			IDE		
Size			Document Number		
B			945P-S3		
Date:			Rev		
Wednesday, August 02, 2006			1.01		
Sheet		of			
26		40			

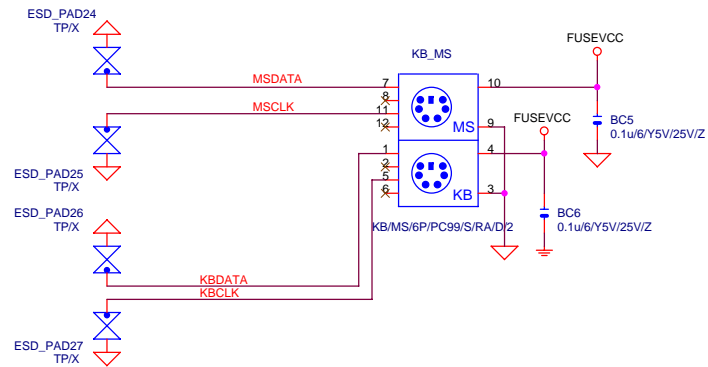
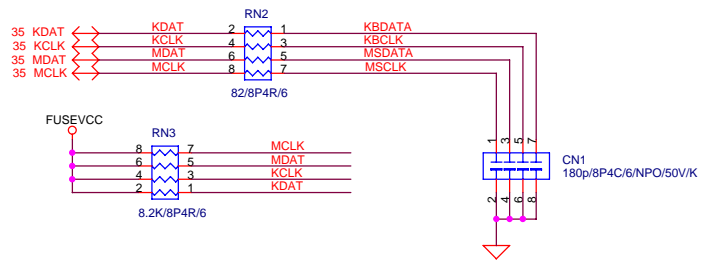
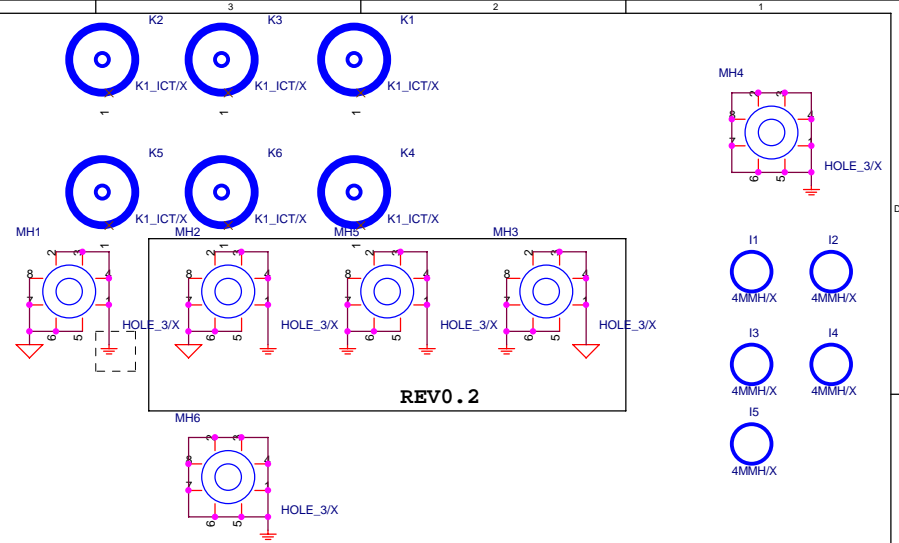
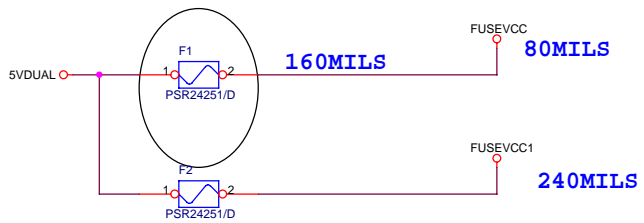

GIGABYTE CORP.			
Title			
KB & PS2 MOUSE & IR			
Size	Document Number	Rev	
B	945P-S3	1.01	
Date:		Sheet	27 of 40

INTEL FRONT PANEL

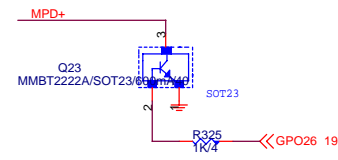
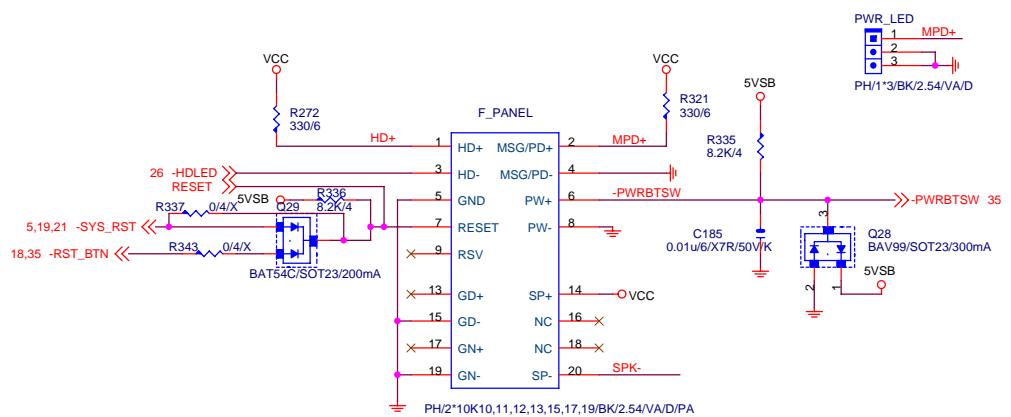

BUZZER

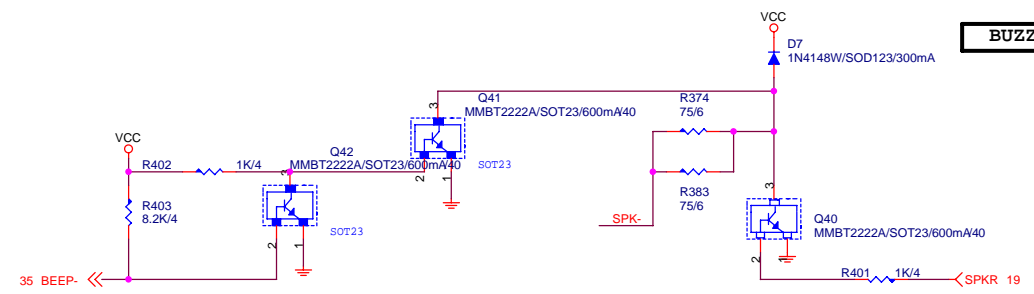

Intel Confidential		
FRONT PANEL		
Size Custom	Document Number 945P-S3	Rev 1.01
Date: Wednesday, August 02, 2006	Sheet 28 of 40	

FRONT USB

90歐姆:[20/7.5/7.5/7.5/20]

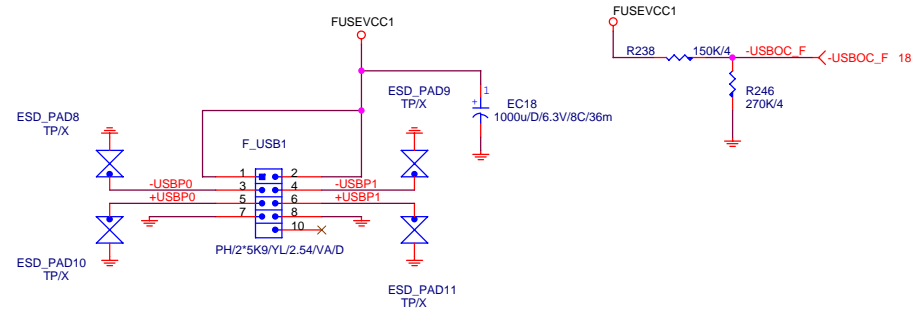

90歐姆:[20/7.5/7.5/7.5/20]

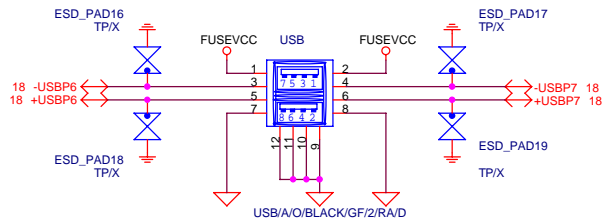
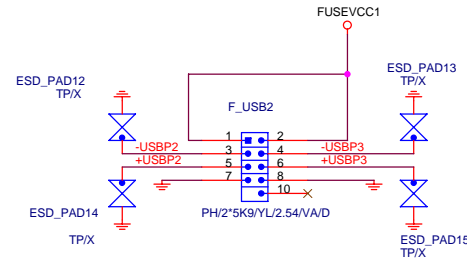
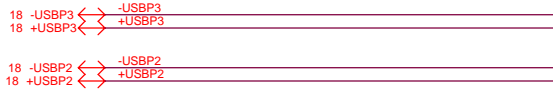

90歐姆:[20/7.5/7.5/7.5/20]

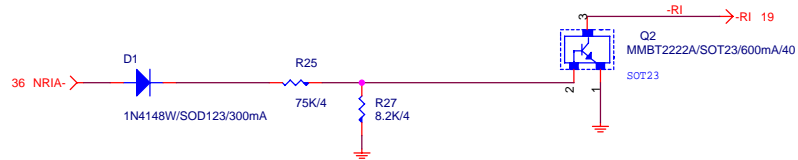
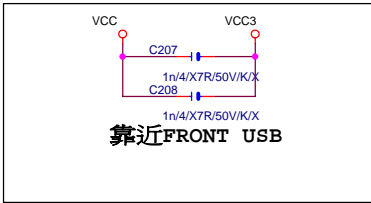
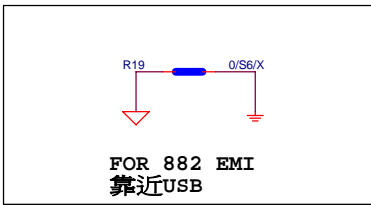

Intel Confidential		
FRONT USB CONNECTOR		
Size B	Document Number	945P-S3
Date:	Wednesday, August 02, 2006	Rev 1.01
	Sheet	29 of 40

asserted at 131 degree
deasserted at 116 degree

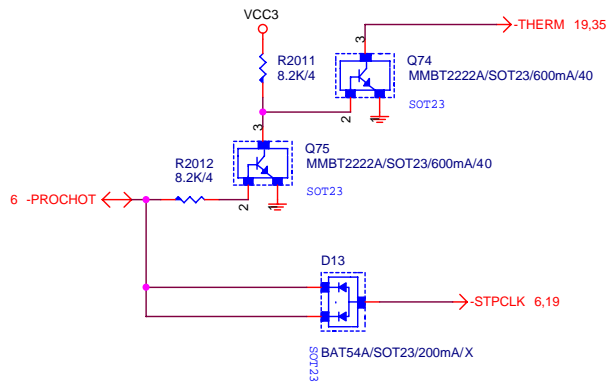
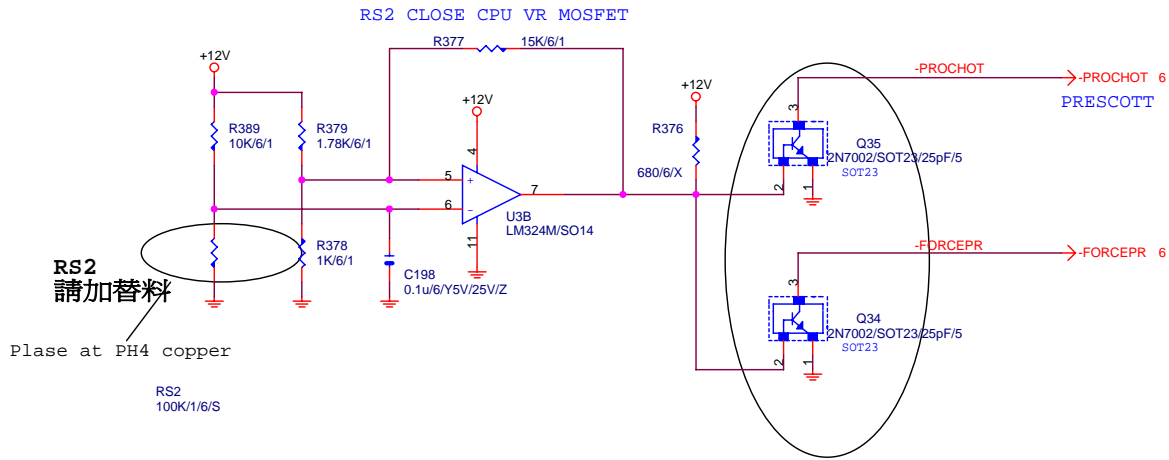

Intel Confidential

Title			FAN CONTROL	
Size B	Document Number	945P-S3		Rev
				1.0
Date:	Wednesday, August 02, 2006	Sheet	30	of 40

AUDIO ALL SIGNAL 50 歌姆:[4/10]

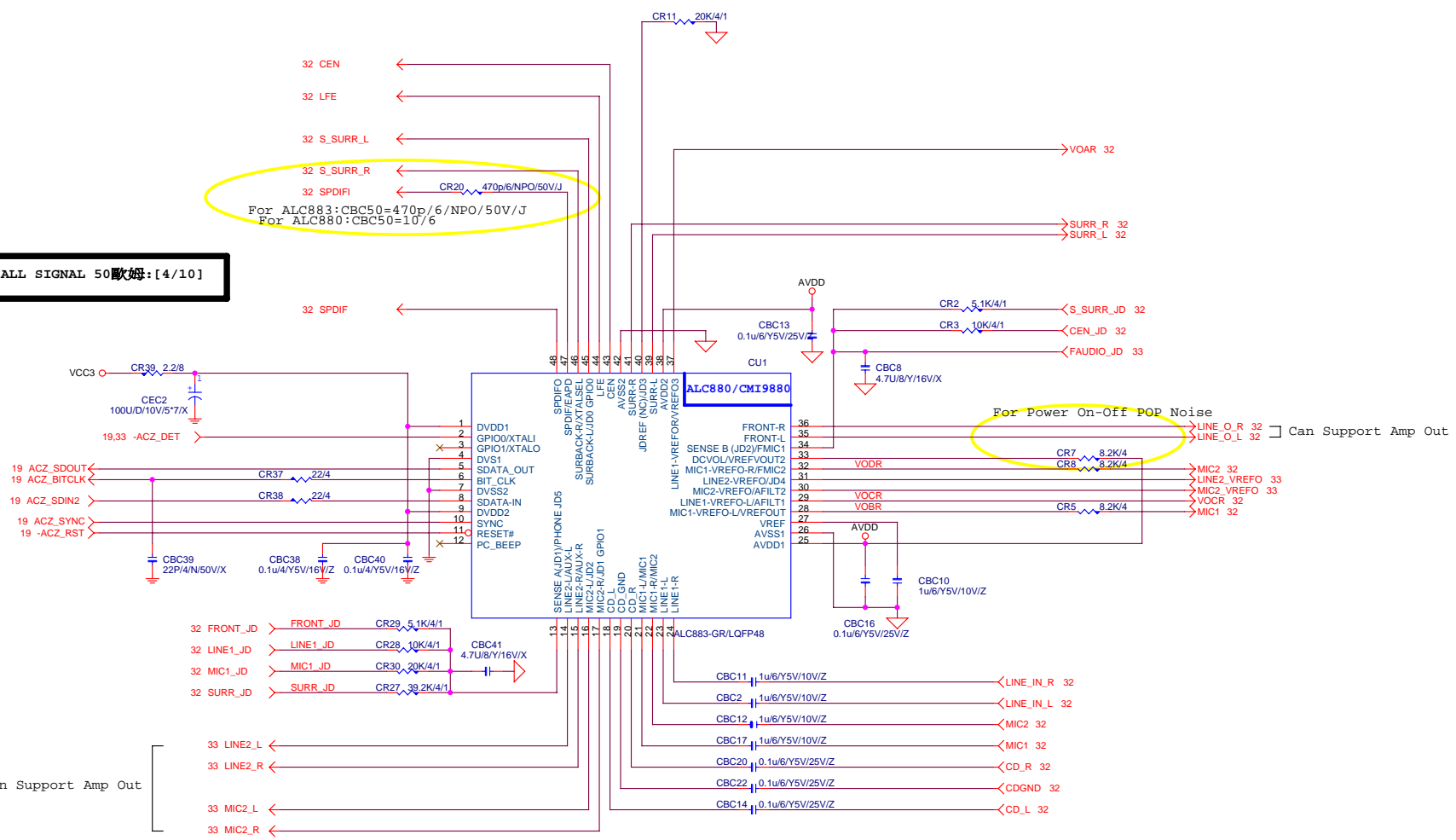

Azalia Port F
Azalia Port E

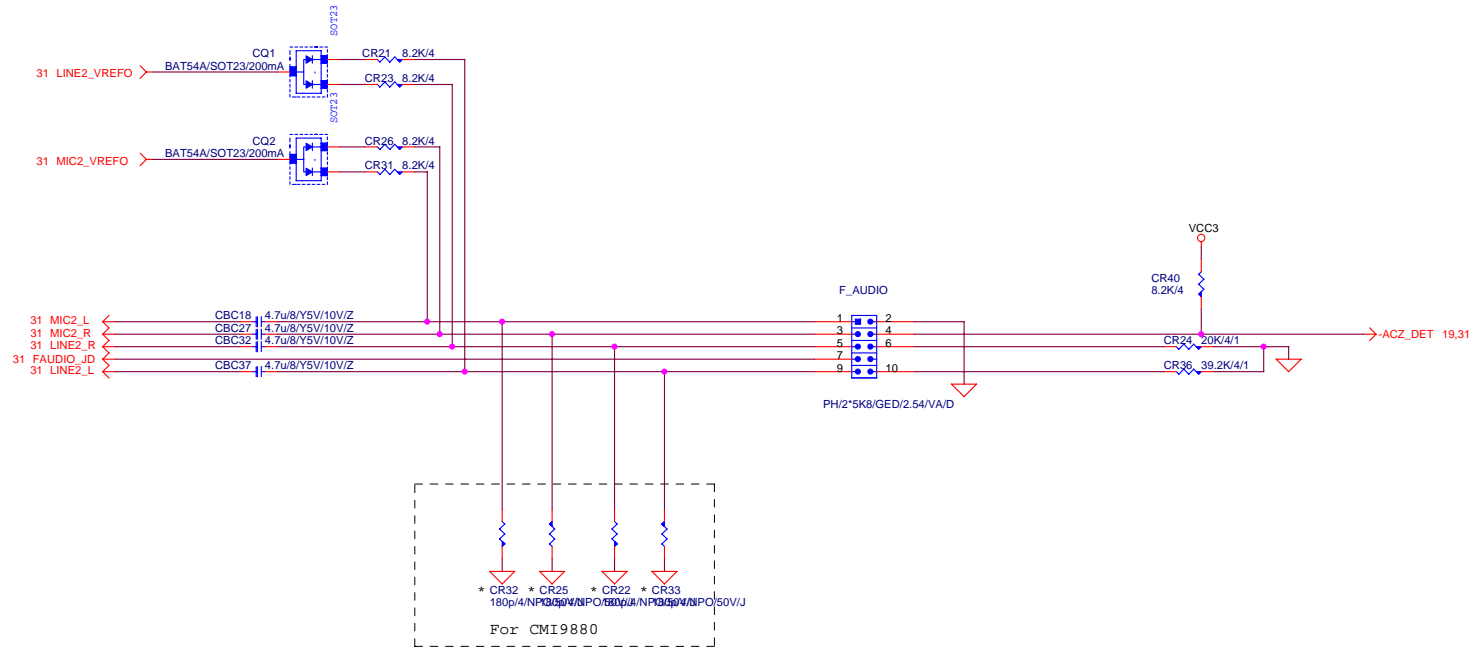

PCIE-1G LAN

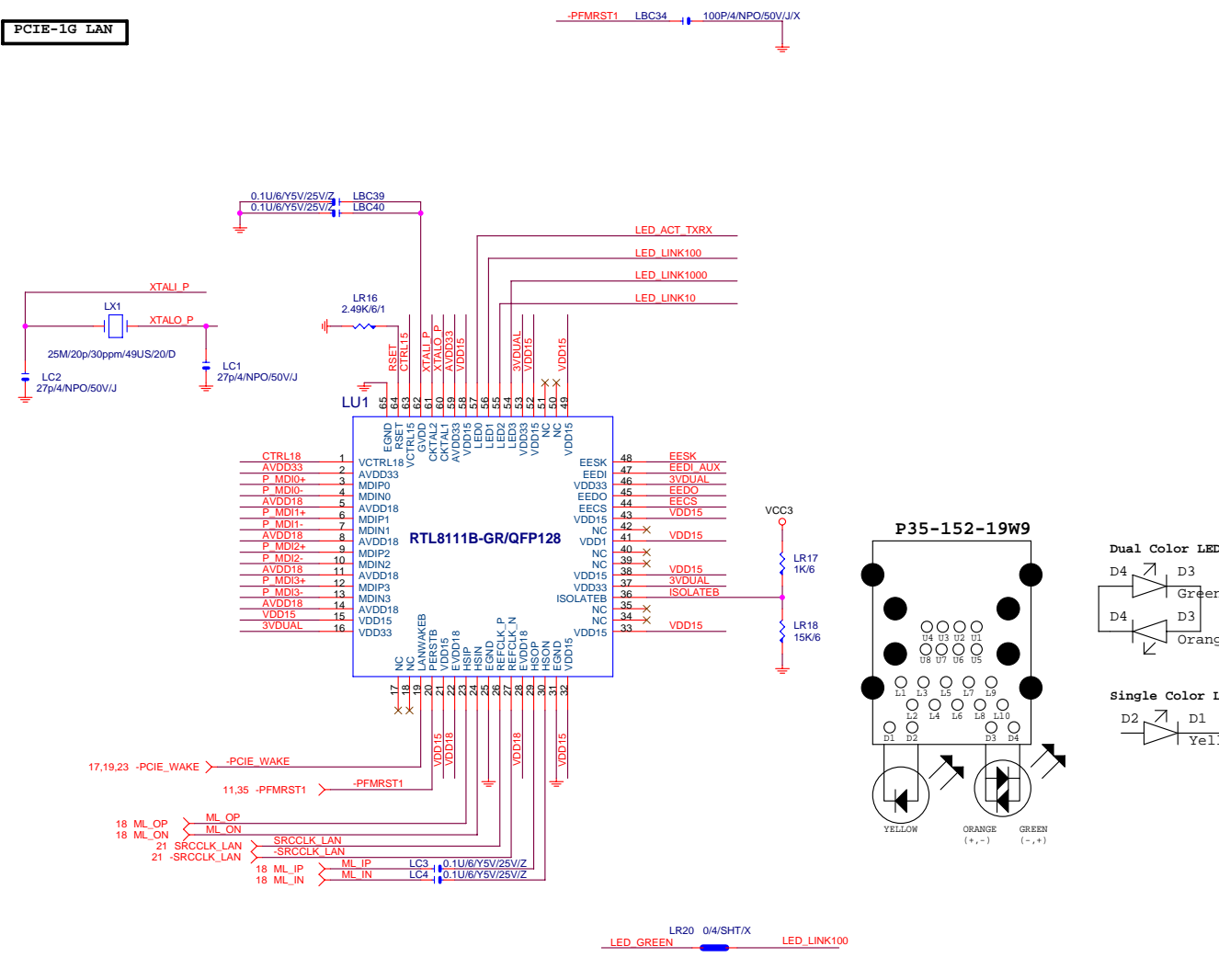

USB_LAN CONNECTOR

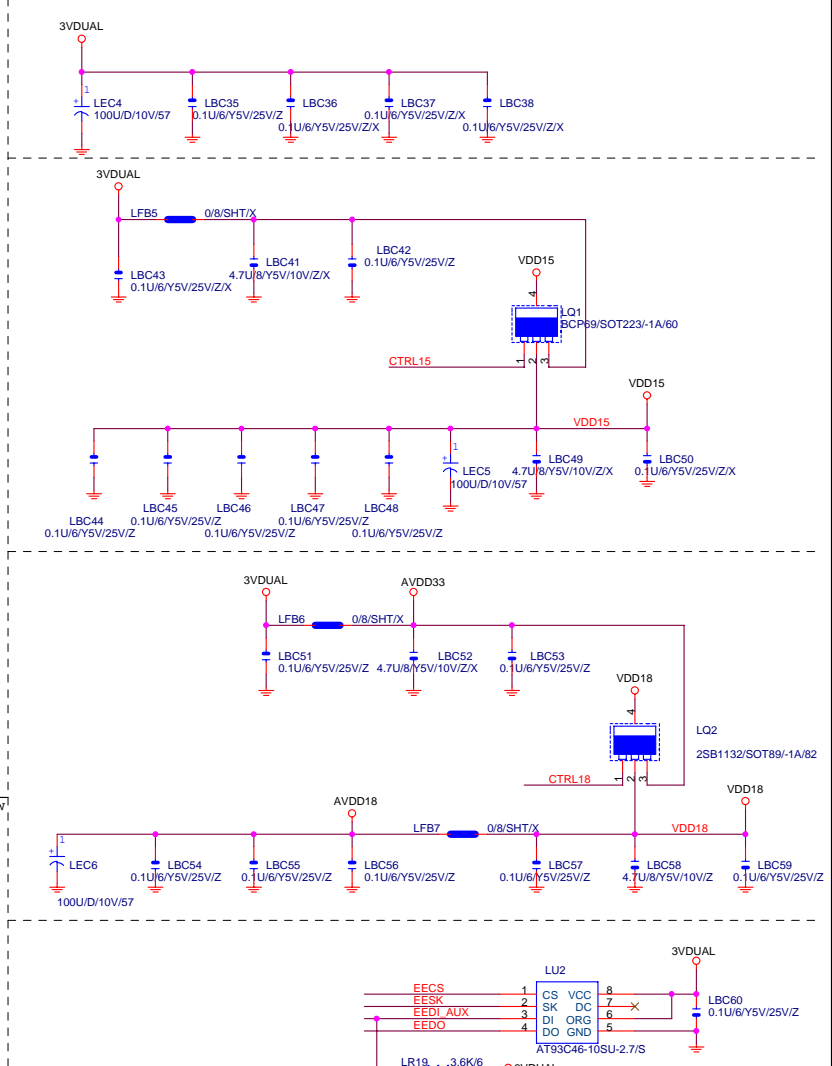
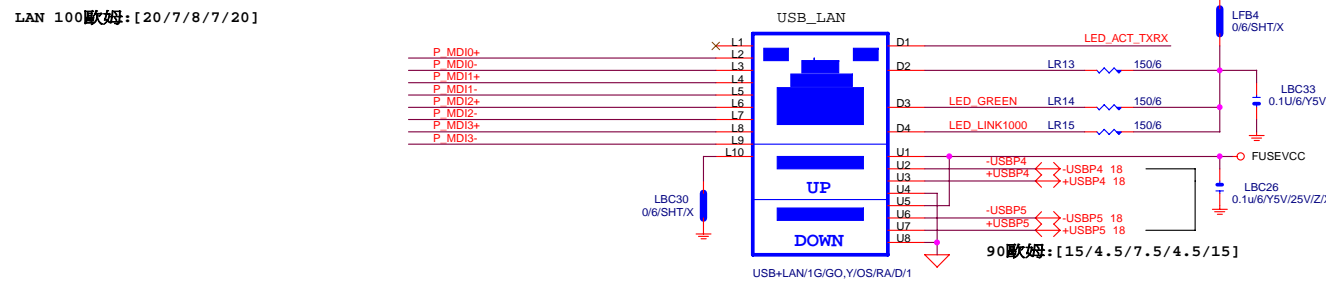

Gigabyte Technology		
REALTEK RTL8111B		
Size Custom	Document Number	Rev
	945P-S3	1.01
Date:	Wednesday, August 02, 2006	Sheet 34 of 40

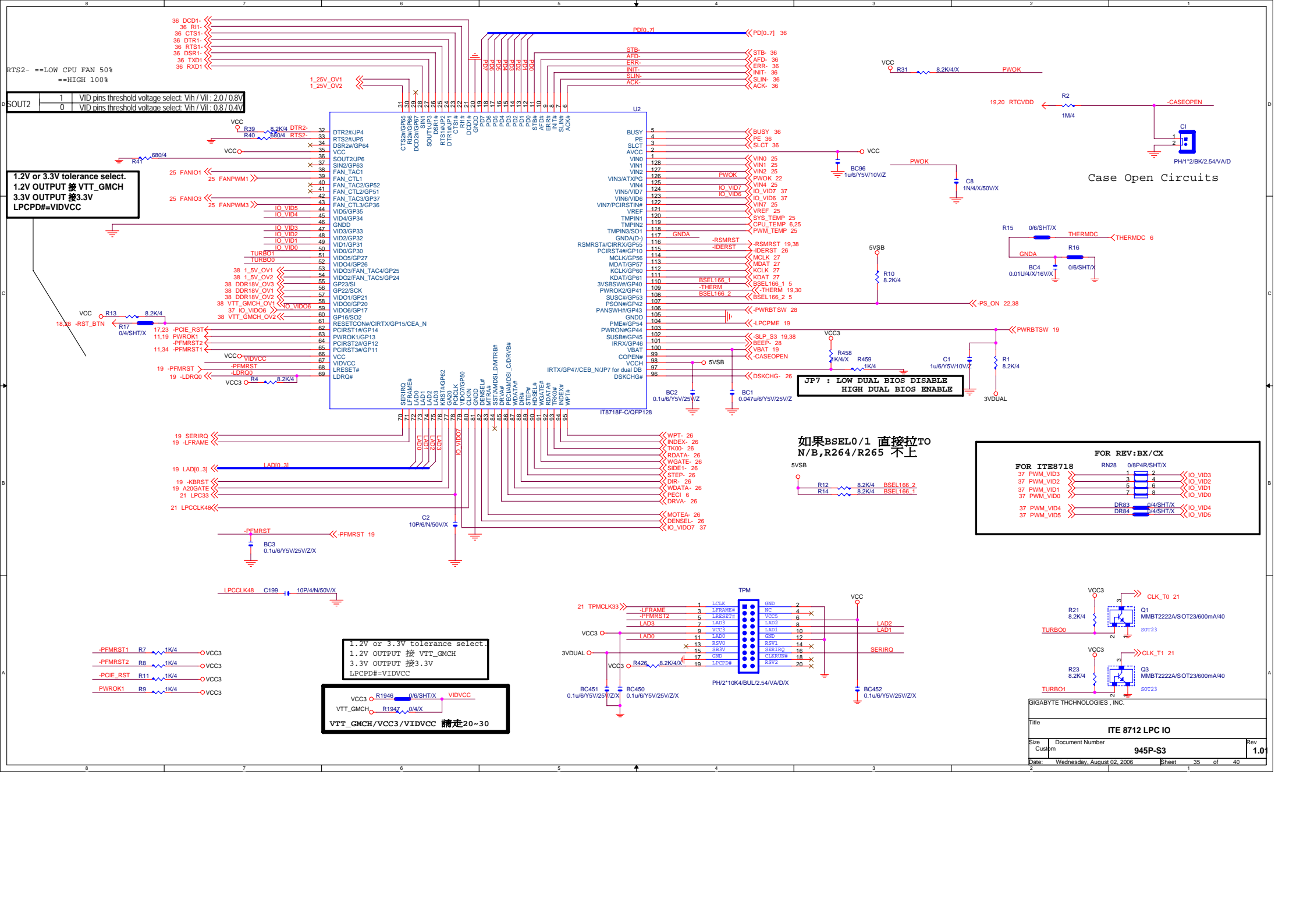

RTS2- ==LOW CPU FAN 50%
 ==HIGH 100%

SOUT2	1	VID pins threshold voltage select: ViH / ViL : 2.0 / 0.8V
	0	VID pins threshold voltage select: ViH / ViL : 0.8 / 0.4V

1.2V or 3.3V tolerance select.
 1.2V OUTPUT 接 VTT_GMCH
 3.3V OUTPUT 接 3.3V
 LPCPD# = VIDVCC

1.2V or 3.3V tolerance select
 1.2V OUTPUT 接 VTT_GMCH
 3.3V OUTPUT 接 3.3V
 LPCPD# = VIDVCC

VCC3 接 R1946 0.6/SHT/X VIDVCC
 VTT_GMCH 接 R1947 0.4/X
 VTT_GMCH/VCC3/VIDVCC 請走 20-30

- PFMRST1 R7 1K/4 VCC3
- PFMRST2 R8 1K/4 VCC3
- PCIE_RST R11 1K/4 VCC3
- PWROK1 R9 1K/4 VCC3

如果 BSEL0/1 直接拉 TO N/B, R264/R265 不上

FOR REV: BX/CX

FOR ITE8718	RN28	0/8P4R/SHT/X	1	2	IO_VID3
			3	4	IO_VID2
			5	6	IO_VID1
			7	8	IO_VID0
	DR83	0/4/SHT/X			IO_VID4
	DR84	0/4/SHT/X			IO_VID5

GIGABYTE TECHNOLOGIES, INC.

Title		ITE 8712 LPC IO	
Size	Document Number	945P-S3	
Custom			Rev 1.0
Date:	Wednesday, August 02, 2006	Sheet	35 of 40

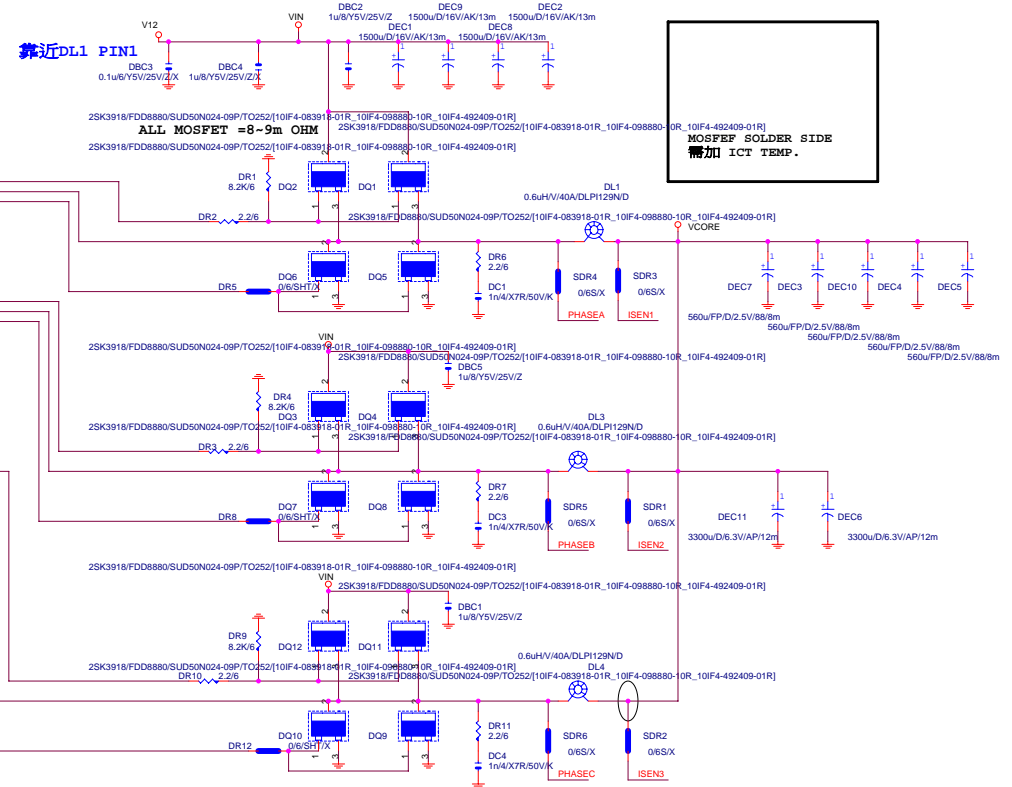
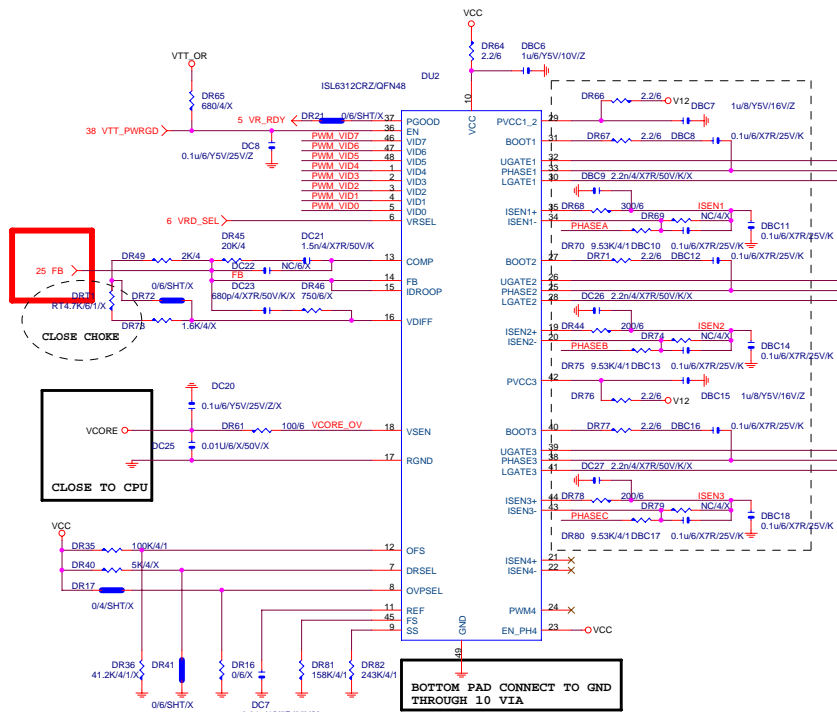

OUTPUT SINK=100uA

I/O OUTPUT SINK=8mA

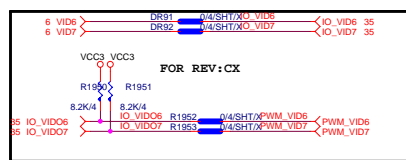
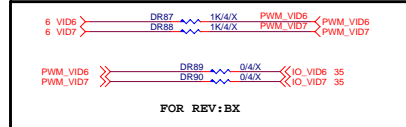
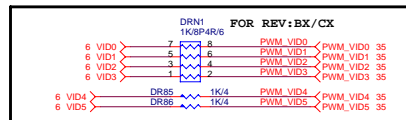
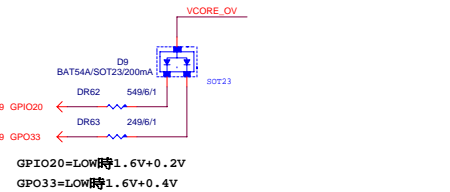
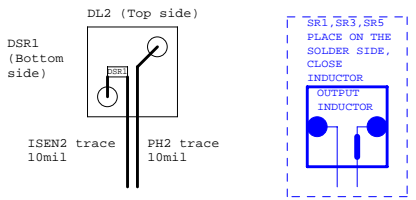

ICH6 GPIO Table:

NAME	PWR LANE	USAGE	NAME	PWR LANE	USAGE
GPI0	V5REF	M/B ID (-REQ6)	GPI41	VCC3	M/B ID
GPI1	V5REF	-REQ5	GPO48	VCC3	-GNT4
GPI2	V5REF	-PIRQE	GPO49	V-CPUIO	CPUPWOK
GPI3	V5REF	-PIRQF			
GPI4	V5REF	-PIRQG			
GPI5	V5REF	-PIRQH			
GPI6	VCC3	-SLP BTN			
GPI7	VCC3	DUAL BIOS			
GPI8	3VDAUL	-LANWAKE			
GPI9	3VDAUL	-USBOC4			
GPI10	3VDAUL	-USBOC5			
GPI11	3VDAUL	-SMBALT			
GPI12	VCC3	ATX DET			
GPI13	3VDAUL	-LPCPME			
GPI14	3VDAUL	-USBOC6			
GPI15	3VDAUL	-USBOC7			
GPO16	VCC3	CPU OV1 (-GNT6)			
GPO17	VCC3	-GNT5			
GPO18	VCC3	CPU OV2			
GPO19	VCC3	DUAL BIOS			
GPO20	VCC3	BIOS T-BLOCK			
GPO21	VCC3	DUAL BIOS			
GPO23	VCC3	DDR OV0			
GPI024	3VDAUL	GREEN LED			
GPI025	3VDAUL	DDR OV1			
GPI26	VCC3	SATA GP0			
GPI027	3VDAUL	+PWRLED			
GPI028	3VDAUL	-PWRLED			
GPI29	VCC3	SATA GP1			
GPI30	VCC3	SATA GP2			
GPI31	VCC3	SATA GP3			
GPI032	VCC3	BIOS WP			
GPI033	VCC3	AZALIA DET			
GPI034	VCC3	PWRLED			
GPI40	V5REF	-REQ4			

PWROK/RESET Table:

ITE8712BHX PIN	NET NAME	TARGET
PIN62/-PCIRST1	-PCIE_RST	1. PCI-E * 1 Slot1 2. PCI-E * 1 Slot2 3. PCI-E * 1 Slot3 4. PCI-E * 16 Slot
PIN64/-PCIRST2	-PFMRST2	1. Onboard PCI Lan 2. Onboard 1394 Chip 3. OnBoard FWH
PIN65/-PCIRST3	-PFMRST1	1. Onboard PCI-E Lan 2. Onboard SATA Chip 3. GMCH
PIN115/-PCIRST4	-PFMRST_ -IDERST	Reserved For IDE
PIN63/PWROK1	PWROK1	1. GMCH 2. ICH6 3. 5VDUAL SWITCH 4. DPS CONTROL
PIN109/PWROK2	-THERM	1. ICH6

GIGABYTE THCHNOLOGIES , INC.

Title			GPIO/RESET TABLE		
Size	Document Number		945P-S3		Rev
Custom					1.01
Date:	Wednesday, August 02, 2006		Sheet	40	of 40